



**SILICON DESIGNS, INC**

**Model 2010**

**DIGITAL ACCELEROMETER MODULE**

- Capacitive Micromachined
- Nitrogen Damped
- Digital Pulse Density Output
- Low Power Consumption
- -55 to +125°C Operation
- Rugged Anodized Aluminum Module
- Four Wire Connection
- TTL/CMOS Compatible
- +5 VDC, 2 mA Power (typical)
- Easy Interface to Microprocessors  
or the model 3320 **G-LOGGER™**
- Good EMI Resistance
- Responds to DC & AC Acceleration
- Non Standard g Ranges Available
- Serialized for Traceability



**DESCRIPTION**

The model 2010 single axis accelerometer module is designed to be used with the model 3020 **G-LOGGER™** Acceleration Acquisition System. Up to three 2010's may be connected to a **G-LOGGER™** using a model 3901 Cable Adapter. The 2010 contains a model 1010L accelerometer which features a micromachined capacitive sense element, a custom integrated circuit sense amplifier, and sigma-delta A/D converter. It provides a TTL/CMOS compatible output signal for measuring accelerations in commercial/industrial environments and is tailored for zero to medium frequency instrumentation applications. The anodized aluminum case is epoxy sealed and is easily mounted via two #4 (or M3) screws. It is relatively insensitive to temperature changes and gradients. An optional calibration sheet (2010-CAL) and periodic calibration checking are available.

**ORDERING INFORMATION**

Full Scale Acceleration	Model Number
± 2 g	2010-002
± 5 g	2010-005
± 10 g	2010-010
± 25 g	2010-025
± 50 g	2010-050
± 100 g	2010-100
± 200 g	2010-200

**OPERATION**

The model 2010 accelerometer produces a digital pulse train in which the density of pulses (number of pulses per second) is proportional to applied acceleration. It requires a single +5VDC power supply and a TTL/CMOS level clock of 100kHz-1MHz. The output is ratiometric to the clock frequency and independent of the power supply voltage. The sensitive axis is perpendicular to the bottom of the package, with positive acceleration defined as a force pushing on the bottom of the package. External digital line drivers can be used to drive long cables or when used in an electrically noisy environment.

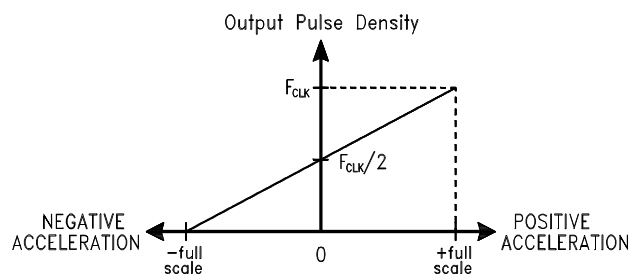

**SIGNALS**

- +5V:** DC Power (red wire)
- GND:** Ground. (black wire, isolated from aluminum case)
- SHIELD:** Cable shield electrically connected to aluminum case.
- CLK:** Input reference clock; 100Khz-1MHz (white wire).
- CNT:** Count (digital pulse stream) output (green wire)

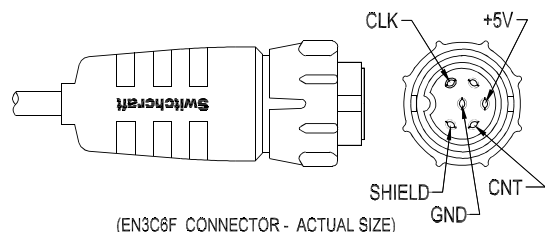



**Model 2010 Digital Accelerometer Module**

**ABSOLUTE MAXIMUM RATINGS \***

Operating Temperature (Case & Cable) . . . . -55 to +125°C  
 Operating Temperature (Connector) . . . . . -40 to +65°C  
 Storage Temperature . . . . . -40 to +65°C  
 Acceleration Over-range . . . . . 2000g for 0.1 ms  
 Voltage on V<sub>DD</sub> to GND . . . . . -0.5V to 6.5V  
 Voltage on CNT or CLK to GND<sup>1</sup> . . . . . -0.5V to V<sub>DD</sub>+0.5V  
 Power Dissipation . . . . . 50 mW

\* **NOTICE:** Stresses above those listed under "Absolute Maximum Ratings" may cause permanent damage to the device. These are stress ratings only. Functional operation of the device at or above these conditions is not implied. Exposure to absolute maximum rating conditions for extended periods may affect device reliability.

**ESD CONSIDERATIONS:** The model 2010 accelerometer is a CMOS device subject to damage by large electrostatic discharges. Diode protection is provided on the inputs and outputs but care should be exercised during handling of the connector or cable wire ends (without connector). Individuals and tools should be grounded before coming in contact with the connector pins or cable wire ends (without connector).

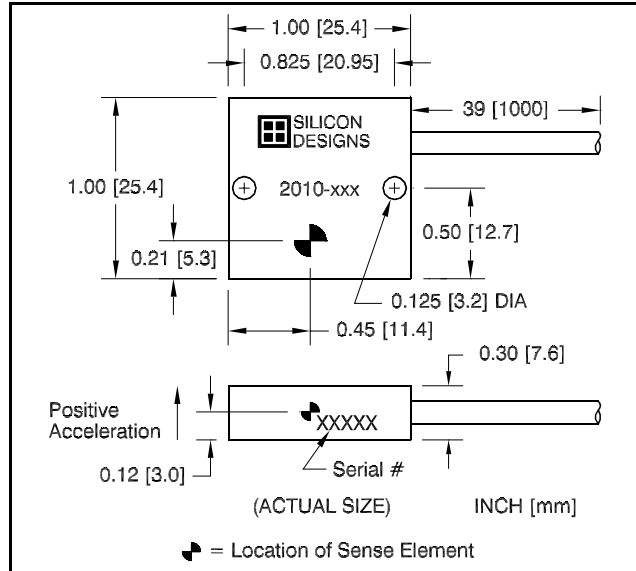

<b>PERFORMANCE - by Model:</b> V <sub>DD</sub> =5.0VDC, F <sub>CLK</sub> =250kHz, T <sub>C</sub> =25°C.									
Model Number	2010-002	2010-005	2010-010	2010-025	2010-050	2010-100	2010-200	Units	
Input Range	±2	±5	±10	±25	±50	±100	±200	g	
Frequency Response (Nominal, 3 dB)	0 - 400	0 - 600	0 - 1000	0 - 1400	0 - 1600	0 - 1800	0 - 2000	Hz	
Sensitivity (F <sub>CLK</sub> =250kHz)	62.5	25.0	12.5	5.00	2.50	1.25	0.625	kHz/g	
Max. Mechanical Shock (0.1 ms)	2000								g

<b>PERFORMANCE - all Models:</b> Unless otherwise specified V <sub>DD</sub> =5.0 VDC, F <sub>CLK</sub> =250kHz, T <sub>C</sub> =25°C.					
PARAMETER	MIN	TYP	MAX	UNITS	
Cross Axis Sensitivity		2	3	%	
Bias Calibration Error <sup>2</sup>	-002	2	4	% of F <sub>CLK</sub> (span)	
	-005 thru -200	1	2		
Bias Temperature Shift (T <sub>C</sub> = -55 to +125°C) <sup>2</sup>	-002	150	400	(ppm of F <sub>CLK</sub> )/°C	
	-005 thru -200	100	300		
Scale Factor Calibration Error <sup>2,3</sup>		1	2	%	
Scale Factor Temperature Shift (T <sub>C</sub> = -55 to +125°C) <sup>2</sup>		+300		ppm/°C	
Non-Linearity (-90 to +90% of Full Scale) <sup>2,3</sup>	-002 thru -100	0.5	1.0	% of span	
	-200	0.7	1.5		
Power Supply Rejection Ratio	40			dB	
Operating Voltage	4.5	5.0	5.5	Volts	
Operating Current <sup>2</sup>		2	3	mA	
Clock Input Voltage Range (with respect to GND)	-0.5		V <sub>DD</sub> +0.5	Volts	
Mass (not including cable)		8		grams	
Cable Mass		25		grams/meter	

- Notes:**
1. Voltages on the CLK & CNT signal wires may exceed 0.5 volt above or below the supply voltage provided the current into or out of the wire is limited to 1 mA.
  2. Tighter tolerances available on special order.
  3. 100g versions and above are tested from -65 to +65g.

**CONNECTOR:** Switchcraft model EN3C6F (mating connector EN3L6M).

**ALTERNATE OUTPUT VERSION AVAILABLE:** A custom version may be ordered which provides the DIR (direction) output instead of the CNT (count) output. For a description of the DIR signal, see the model 1010 data sheet.

SPECIFICATIONS SUBJECT TO CHANGE WITHOUT NOTICE



**Model 2010 Digital Accelerometer Module**

**SIGNAL DESCRIPTIONS**

**CLK (input):** Reference clock input. This hysteresis threshold input must be driven by a 50% duty cycle square wave signal. Factory Calibration is performed at 250 kHz but the 2210 will operate at frequencies as low as 100 kHz or as high as 1 MHz.

**CNT (output):** Count output. A return-to-zero type digital pulse stream whose pulse width is equal to the input CLK logic high time. The CNT pulse rate increases with positive acceleration. The device experiences positive (+1g) acceleration with its lid facing up in the earth's gravitational field. This signal is meant to drive an up-counter directly.

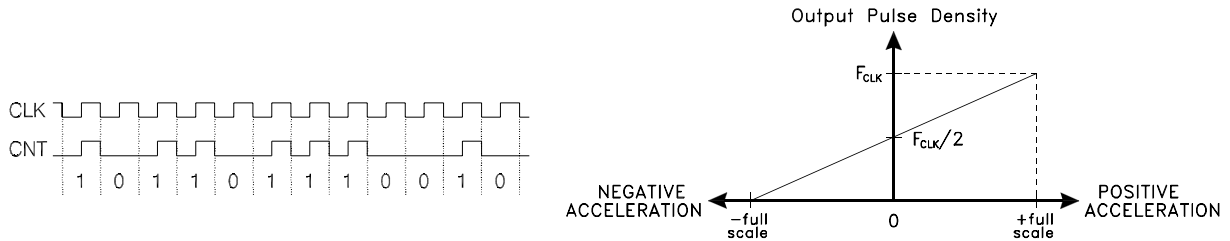

Pulses from the CNT output are meant to be accumulated in a hardware counter. Each pulse accumulation or sample, reflects the average acceleration (change in velocity) over that interval. The sample period or "gate time" over which these pulses are accumulated determines both the bandwidth and quantization of the measurement.

$$\text{Quantization (g's)} = \frac{g_{SPAN} \cdot f_{SR}}{f_{CLK}}$$

$$f_{CNT} = f_{CLK} \left( \frac{1}{2} + \frac{g_{FORCE}}{g_{SPAN}} \right)$$

$$g_{FORCE} = g_{SPAN} \left( \frac{f_{CNT}}{f_{CLK}} - \frac{1}{2} \right)$$

Where:

$$g_{SPAN} = 2 * (\text{full scale acceleration in g's})$$

$$f_{SR} = \text{CNT sample rate in Hertz}$$

$$f_{CLK} = \text{accelerometer clock rate in Hertz}$$

$$f_{CNT} = \text{CNT pulse rate in pulses / sec}$$

$$g_{FORCE} = \text{acceleration in gravity units}$$

$$1 \text{ g} = 9.807 \text{ m/s}^2 \text{ or } 32.175\text{ft/s}^2$$

The first equation above shows that as the sample rate is reduced (i.e. a longer sample period), the quantization becomes finer but bandwidth is reduced. Conversely, as the sample rate is increased, quantization becomes coarser but the bandwidth of the measurement is increased. The second and third equations show how the CNT pulse frequency equates to the applied g-force. When using a frequency counter to monitor the CNT output pulse rate, a counter with a DC coupled input must be used. The CNT output is a return-to-zero signal whose duty cycle varies from zero to fifty percent, from minus full scale to positive full scale acceleration. A frequency counter with an AC coupled input will provide an erroneous reading as the duty cycle varies appreciably from fifty percent.

**CABLE LENGTH CONSIDERATIONS**

Cable lengths of up to 45 meters (150 feet) can be added to the model 2010's standard 1 meter cable when it is connected to a Model 3901 Adapter Cable and is being used with a Model 3320 **G-LOGGER™**. The extension cable must however, be a longer version of the **G-LOGGER™** 9 conductor flat cable instead of the 2010's round cable to reduce crosstalk between the CNT and CLK signals. 15 meter (50 foot) cable lengths of DB9 male to DB9 female flat extension cable are available on special order.