



F2i

10,000 Nm

1 Channel

Torquemeter

with integrated evaluation unit

Description

This bearingless torque measurement system represents an extension to the known types F1 and F2. This variant needs no external evaluation unit for operation. The electronic unit is integrated into the stator and provides the frequency output $60 \text{ kHz} \pm 20 \text{ kHz}$ as well as additional features for the further processing and monitoring.

A high end temperature compensation guarantees a very high stability and repeatability of the output signal. A special configured magnetic sensor provides two 90 degree phase shifted speed signals with 1,024 ppr. The maximum frequency is 250 kHz. The extension to a double telemetry system allows to equip this unit with a second torque measurement range.

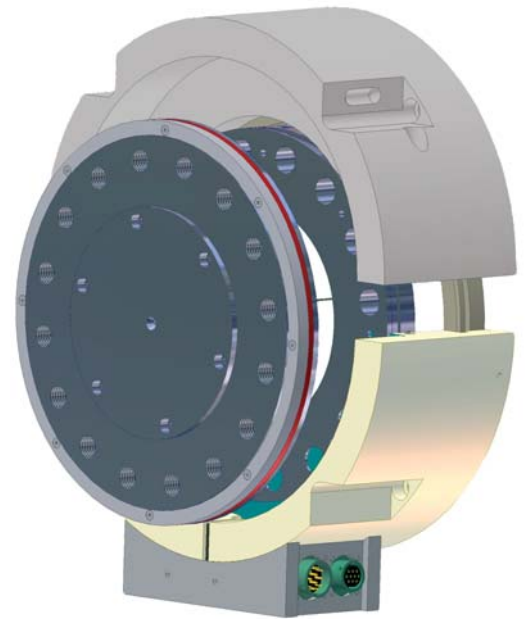

Significant technical data

- Bearingless torque flange with IR-signal transmission
- Evaluation unit integrated in stator
- High overload capability
- Active temperature compensation to reduce temperature effect on zero balance
- Accuracy 0.1 (Option 0.05)
- Magnetic speed encoder (1,024 ppr)
- Option: 2 torque ranges (span up to 1:10)
- Compact design
- Fits to cardan shaft types 228 and 587
- Transmission of characteristic values

GESELLSCHAFT FÜR INDUSTRIEFORSCHUNG MBH

Konrad-Zuse-Str. 3
D - 52477 Alsdorf / Germany
Tel.: +49 (0)2404-9870-570
Fax: +49 (0)2404-9870-59
www.gif.net
info@gif.net



Rated torque T_r	Nm	$\leq 10,000$
Overload capability torsional shaft	Nm	$5T_r$
Accuracy including hysteresis and nonlinearity	% FS.	$< \pm 0.1$
Temperature effect on zero	% FS./10K	$< \pm 0.1$
Operating temperature range	°C	0...+70
Rated speed	rpm	10,000

Technical Data Torquemeter Type F2i

TORQUEMETER

Rated torque nominal T_r	Nm	$\leq 10,000$
Torque limit of torque shaft related to T_r	Nm	$> 5T_r$
Rated speed n_r	rpm	10,000
Accuracy	-	0.1
Nonlinearity and hysteresis related to T_r	%	$< \pm 0.1$
Temperature effect on zero per 10K related to T_r	%	$< \pm 0.1$
Nominal temperature range	$^{\circ}\text{C}$	0...+70
Operating temperature range	$^{\circ}\text{C}$	-10...+80

OUTPUT SPECIFICATION TORQUE

Frequency output	kHz	60 ± 20
Dynamic response up to	kHz	2
Analog output	V DC	0...10
Analog output	mA	0...20 / 4...20
Conversion rate / resolution	MV/s	1,000 with 16bit
Shunt calibration	-	approx. 30% of T_r

OUTPUT SPECIFICATION SPEED (OPTIONALLY)

Pulses per rev (magnetic encoder)	-	1,024
Output signal (RS422) Frequency	-	2 tracks 90° phase shifted
Output signal analog	V DC	0...10
Conversion rate / resolution	MV/s	1,000 with 16bit
Required speed	rpm	> 0

ADDITIONAL INTERFACES / FEATURES

Serial interface RS232	Baud	19,200
CAN Bus		CAN2B
Internal temperature sensing in stator		

MECHANICAL DATA

Weight (rotor)	kg	approx. 14
Inertia (rotor)	gm^2	approx. 87.5
Twist angle under rated torque	grad	0.05
Torsional stiffness	kNm/rad	2,298
Coupling mass (typ.)	kg	20
Fits to cardan shafts	-	Type 228 and 587

OPTIONS

Nonlinearity and hysteresis related to T_r	%	$< \pm 0.05$
Temperature effect on zero per 10K related to T_r	%	$< \pm 0.05$
2nd torque range	Nm	up to $1/10 T_r$

Order Number

F2i-5000-1024-KLN

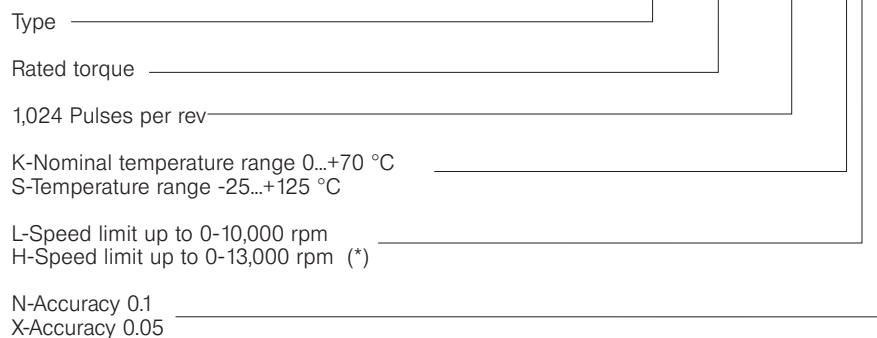

(*)=without speed detection

Dimensions Torquemeter F2i

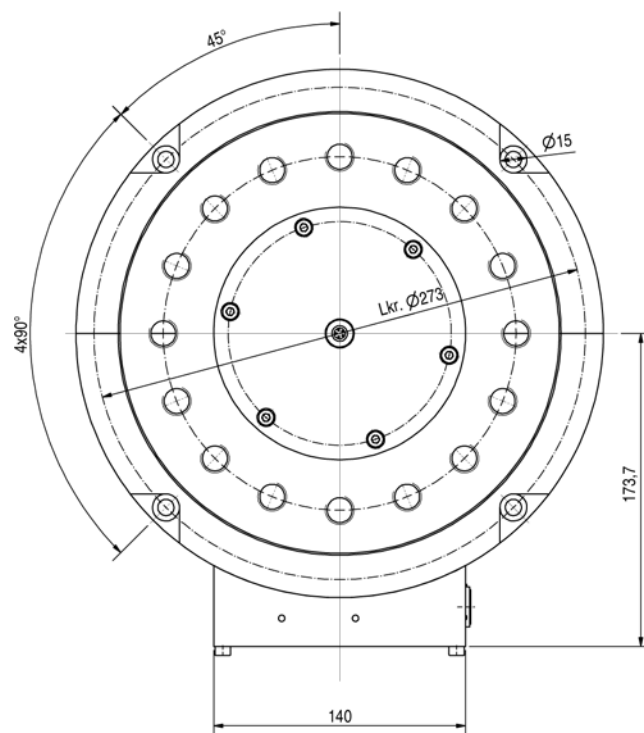
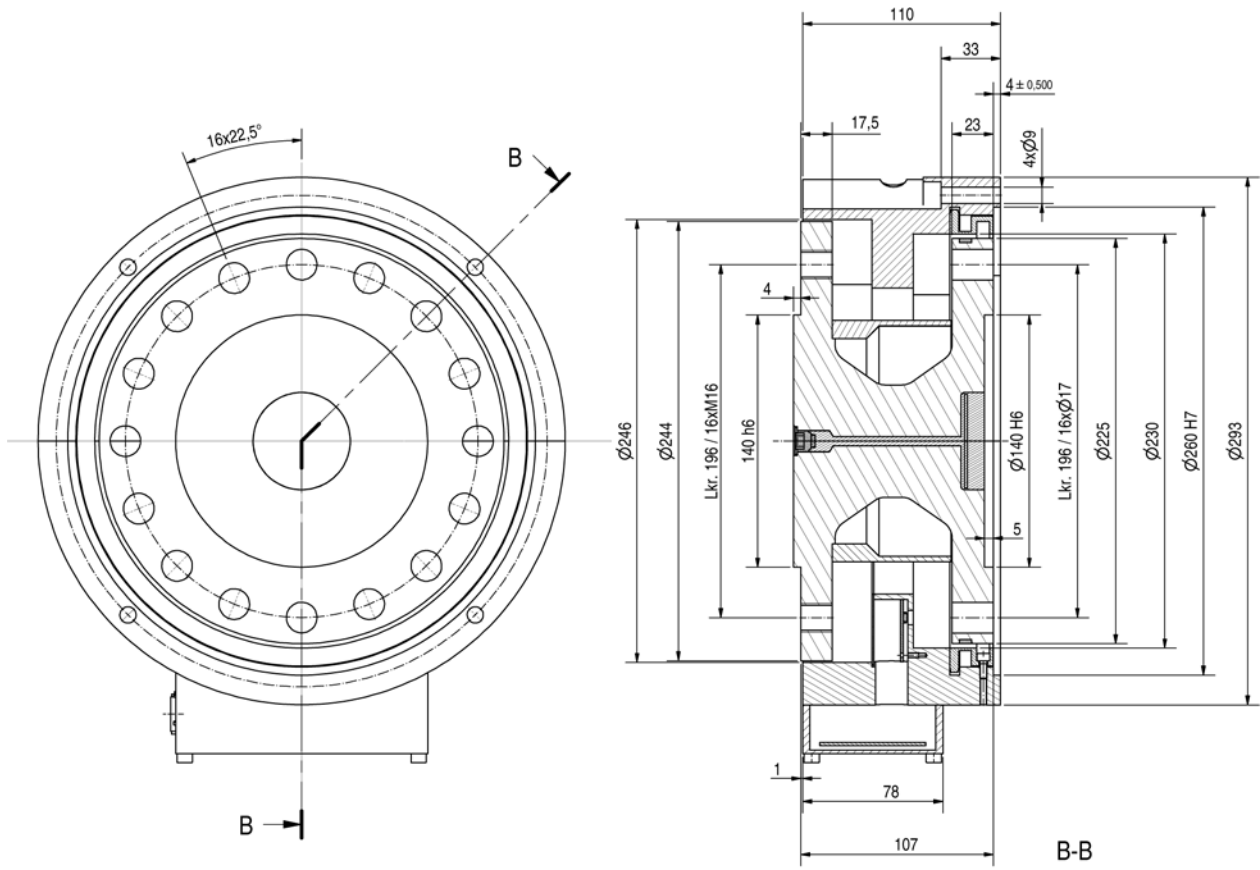

Opportunities of evaluation with measuring flange F2i

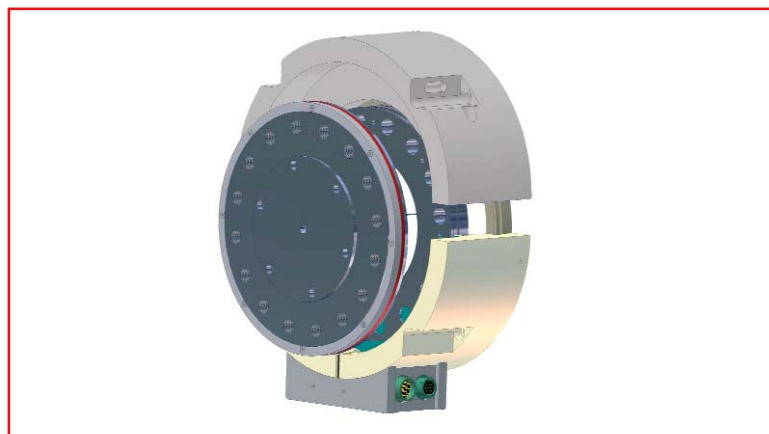

Alternative evaluation
with TCU 19



Power supply		
Voltage	24 V DC / 1 A	85...264 V AC
Output specification torque		
Frequency	60 kHz \pm 20 kHz RS422	60 kHz \pm 20 kHz TTL / RS422
Analog	Voltage: 0...10V DC Current: 0...20 mA, 4...20 mA Conversion rate: 1,000 MV/s	Voltage free scalable e.g. \pm 10 V DC Rate of converting: 1,000 MV/s (optional 2 kHz)
Output specification torque (optionally)		
Ps./rev.	1,024	Depending on sensor
Frequency	max. 2x250 kHz / 90° phase shifted RS422	max. 2x250 kHz / 90° phase shifted RS422 / TTL
Analog	Voltage: 0...10 V DC Conversion rate: 1,000 MV/s	Voltage: free scalable e.g. \pm 10 V DC Conversion rate: 1,000 MV/s
Serial terminal		
Serial terminal	RS232	RS232
CAN-BUS		
CAN-BUS	CAN2B up to 1MBit	CAN2B up to 1MBit
External (Remote)		
Remote	Via additional control line	Optocoupler input
Display		
Display	-	Touch screen display
Options		
2. Measuring range	yes	yes
Additional temperature sensing	-	8-channel
2. Measuring flange	-	yes
Vibration sensor in stator	yes	-
Temperature measurement in stator	yes	-
Status output	Additional control line one-channel, assignable either with status signal or temperature channel	yes

