



KMT - Kraus Messtechnik GmbH



Gewerbering 9, D-83624 Otterfing, Germany, ☎ 08024-48737, Fax. 08024-5532
Home Page <http://www.kmt-gmbh.com>, Email: info@kmt-gmbh.com

CT2-Wheel - User Manual

2 Channel Wheel Telemetry System

Including signal conditioning for STG, Th-K, Pt100, ICP, POT
or high-level inputs



- STG offset via potentiometer or optional Auto Zero calibration
- 12 bit ADC resolution, simultaneous sampling of all channels
- Signal bandwidth: 2 x 0-375Hz
Scanning rate: 2x 1428Hz
- Water protected housing (IP65)
- Output analog (+/- 5V) and digital for PC interface at the receiver side
- Universal mounting adapter for fast and exactly montage on the wheel
- 4x different carrier frequencies enable measurements at 4 Wheels for one car
- Accumulator powered (up to 36h)

General functions CT2-Wheel:

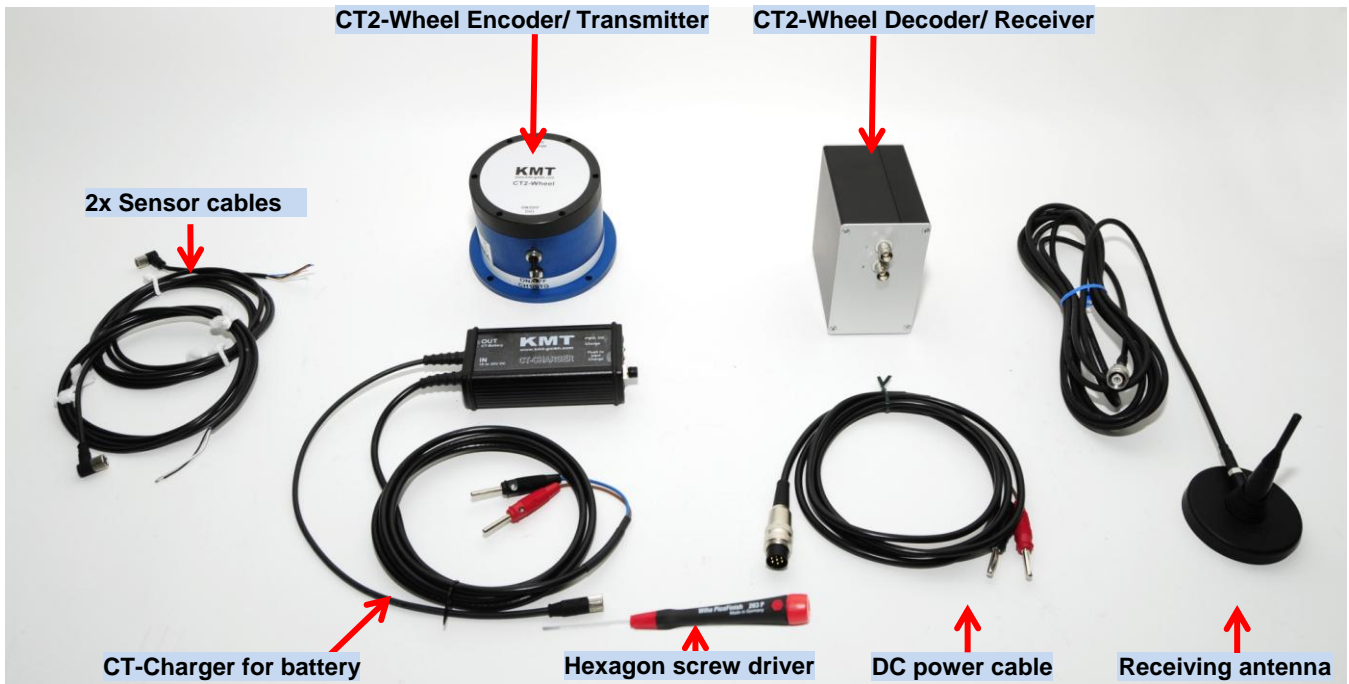

CT2-Wheel Telemetry system with accessories

CT2-Wheel is a telemetry system designed for easy mounting onto rotating wheels to provide non-contact transmission of measured parameters such as pressure, force, temperature, acceleration and voltage.

Sensors inputs are connected via screw on, waterproof connectors. Measured values are prepared in analog format, digitized and transmitted via radio frequencies. Four different carrier frequencies are provided, this allows up to four systems (e.g. for four wheels) to operate in parallel. The complete transmitter assembly is waterproofed to IP65 specifications.

The following sensors can be connected to the system: (STG) Strain gages sensors in full-, half- and quarter-bridge configuration (350 ohm or greater), Type K Thermocouples -50 to 1000°C (**full galvanic isolated**), ICP and capacitive sensors. Voltage inputs of +/-5V and +/-10V are available.

The measured values are processed and output as +/-5V analog signals at the BNC sockets (optional digital output for special PCM interface into a PC) on the stationary receiver located in a vehicle.

Resolution of 12 bits is standard; this enables an amplitude dynamic of 72 dB. The analog signal bandwidth is 0-95 Hz (-3dB) when configured as an eight channel unit, other bandwidth on request! The measurement accuracy is +/-0.25 % (without sensor). The CT2-Wheel is suited for operation at ambient temperatures of -20 to +70°C. The transmission distance between transmitter and receiving antenna is of the order of 10m (30 feet) - depend of application!



Application pictures of CT8-Wheel

CT2-Wheel Transmitting Unit Technical Data (Encoder)



CT-STG-V1:

Sensor:	strain gage, > 350 Ohms
Bridge completion:	full and half bridge
Excitation:	4 VDC (fixed), short-circuit protection up to 20mA
Gain:	200 or 1000 - selectable by solder jumpers Optional Gain: 250-500-1000-2000 with new CT-STG-V2 module
Offset	Zero adjustment by potentiometer or <u>optional</u> Auto-zero function (which is not lost by power-off), offset range up to 80% of full scale.
Signal bandwidth:	0...375 Hz -3dB (<u>optional</u> 0-3000Hz)

CT-ICP:

Constant current:	1, 4, or 10mA
Gain:	2x, 4x, 8x, 16x or 32x
Signal bandwidth:	3...375 Hz -3dB (<u>optional</u> 3-3000Hz)

CT-POT:

Sensor:	Potentiometer Sensor >350 Ohms to 10kOhms
Excitation:	4 VDC (fixed)
Signal bandwidth:	0...375 Hz -3dB (<u>optional</u> 0-3000Hz)

CT-TH-K-ISO:

Sensor:	thermo-couple, type K (with cold junction compensation)
Temperature measuring range:	-50°C to +1000°C (other on request) with galvanic isolation, Accuracy 1%
Signal bandwidth:	0...10 Hz -3dB

CT-PT100:

Sensor:	resistance temperature detectors (RTDs) with resistance of 100 ohm
Temperature measuring range:	-100°C to +500°C

CT-VOLT:

High-level inputs:	+/- 5 Volt or +/- 10 Volt
Signal bandwidth:	0...375 Hz -3dB (<u>optional</u> 0-3000Hz)

System Parameters:

Channels:	2
Resolution:	12 bit A/D converter with anti aliasing filter, simultaneous sampling of all channels
Line-of-sight distance:	20m with 10mW transmitting power, (868MHz Band, FSK modulation)
Powering:	7.2mA Li-Ion battery 1350mAh 12h operating time , <u>optional</u> 4000mAh for 36h
Power consumption:	100 mA with 2 STG sensors at 350 Ohms full bridge
Analog signal bandwidth:	2 x 0 ... 375Hz with 40 kbit/s transmitter (-3dB cut-off frequency at receiver side)
Transmitter carrier frequency:	4 HF-Channels in the 868MHz range
Transmission:	Digital PCM Miller format - FSK
Transmission Power:	10mW, range of 10m
Dimensions:	Diameter 102mm, bottom plate diameter 122mm, height 94mm
Weight:	0.900 kg without cables
Operating temperature:	- 20 ... +70°C
Housing:	Aluminum anodized, waterproofed (IP65)
Humidity:	20 ... 80% no condensing
Vibration:	5g Mil Standard 810C, Curve C
Static acceleration:	100g in all directions
Shock:	200g in all directions

Technical data: Receiving Unit CT2-Wheel DEC (Decoder)

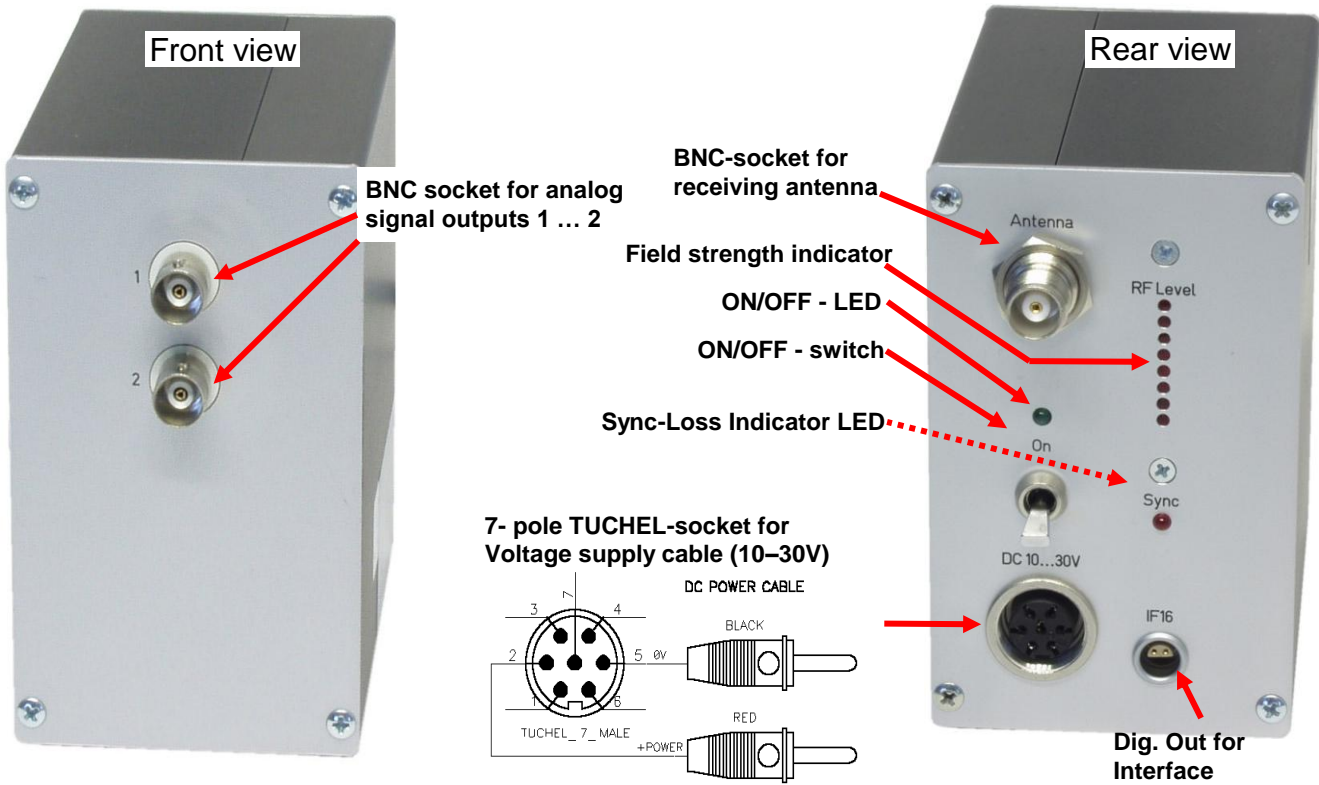

System Parameters:

Channel:	2 analog outputs via (BNC) +/-5V
Resolution:	12 bit D/A converter, with smoothing filter
Dynamic:	72dB
Power supply input:	10-30 VDC
Current consumption:	300mA at 10V, 100mA at 30V
Carrier frequencies:	4 HF-Channels in the 868MHz range with 40 kbit/s transmitting rate FSK modulation
Dimensions:	105 x 105 x 65mm
Weight:	0.60 kg without cables and antenna
Overall system accuracy between encoder input and decoder output:	+/-0.25% without sensor influences
<u>Environmental</u>	
Operating:	-20 ... +70°C
Humidity:	20 ... 80% not condensing
Vibration:	5g Mil Standard 810C, Curve C
Static acceleration:	10g in all directions
Shock:	100g in all directions

Technical specifications are subject to change without notice!

**Functions:
2 Channel CT2-Wheel ENC (encoder/transmitter)**

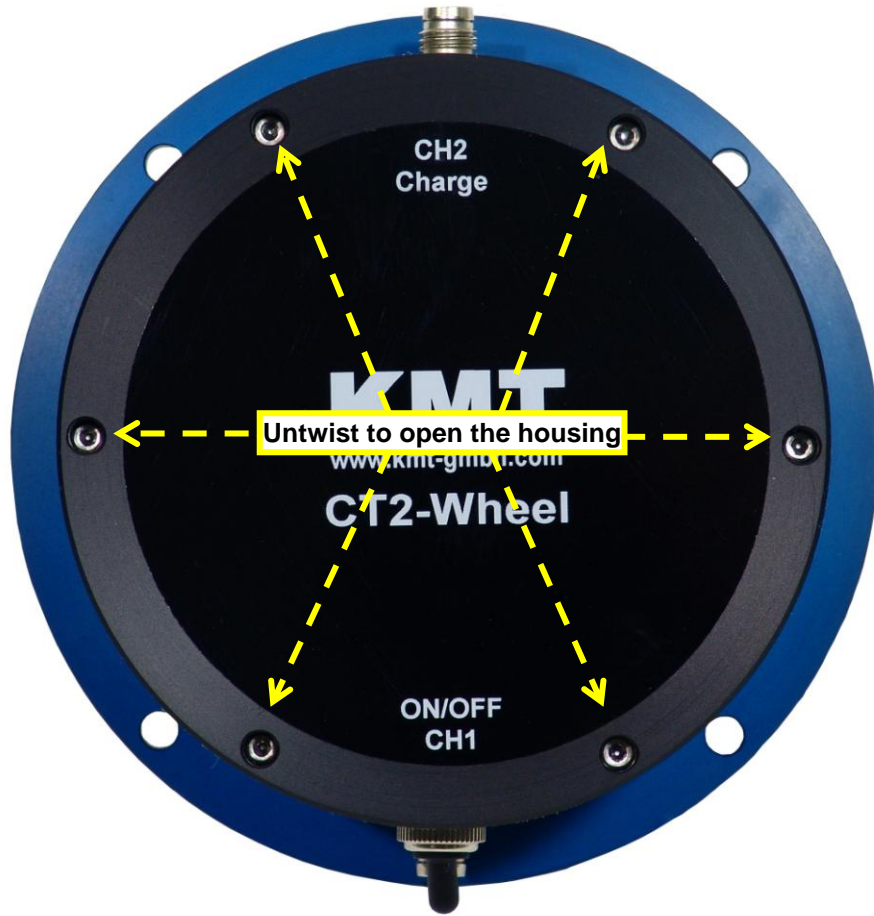

Connection, STG bridge configuration: CT2-Wheel ENC (encoder)

 <p>Sensor cable</p>	<p>Black = IN - White = IN + Brown = EXC + Blue = EXC -</p>	 <p>Sensor socket</p>	<p>STG module</p> <p>Type: Strain gage >350 Ohms Excitation: 4 VDC (fixed) Gain: 200 or 1000</p> <div style="display: flex; justify-content: space-around;"> <div style="text-align: center;"> <p>+ IN (White)</p> </div> <div style="text-align: center;"> <p>-- IN (Black)</p> </div> </div> <div style="display: flex; justify-content: space-around;"> <div style="text-align: center;"> <p>+ EXC (Brown)</p> </div> <div style="text-align: center;"> <p>-- EXC (Blue)</p> </div> </div> <p style="text-align: right;">Sensor plug CT2-Wheel ENC</p> 
---	---	--	---

1/1 or 1/2 Bridge setting

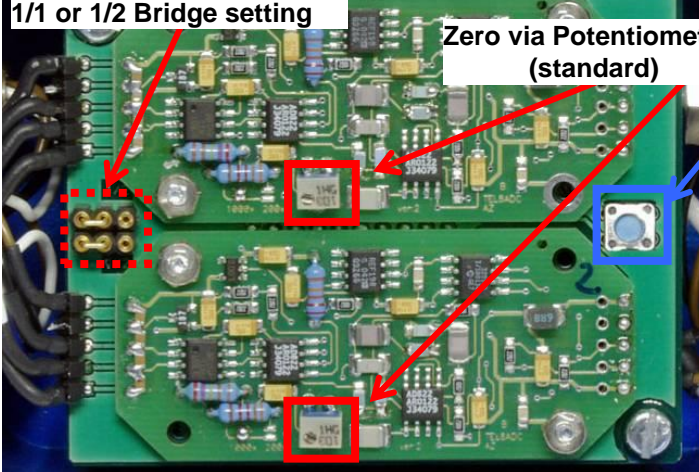

Zero via Potentiometer (standard)

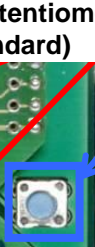

Auto Zero Switch (Option) Only for STG







CT-STG-Version V1 Gain 200 or 1000 by solder bridge

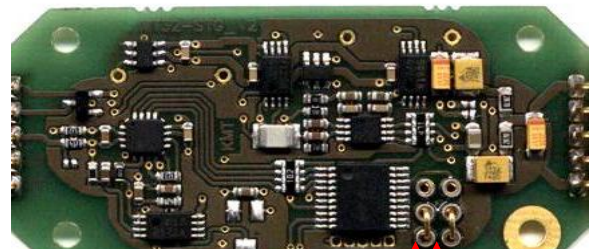

Gain 1000 Gain 200

CT-STG-Version V2 Gain 25-500-1000 or 2000 by jumper







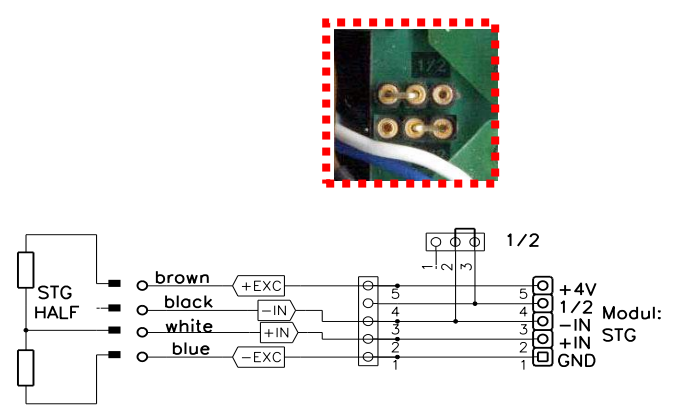
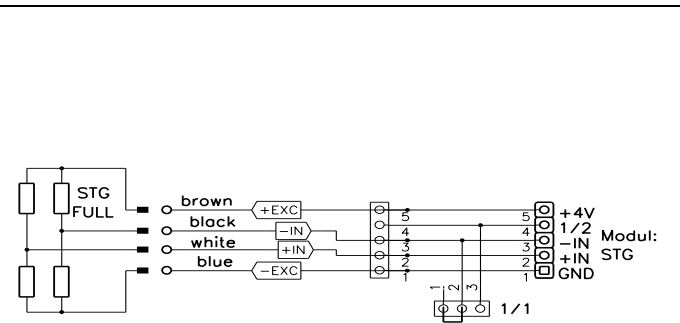

<p>SB 1 SB 2</p> <p>GAIN = 250 (1000)</p> 	<p>SB 1 SB 2</p> <p>GAIN = 1000 (4000)</p> 
<p>SB 1 SB 2</p> <p>GAIN = 500 (2000)</p> 	<p>SB 1 SB 2</p> <p>GAIN = 2000 (8000)</p> 



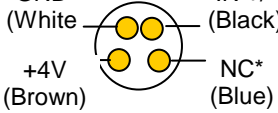

Gain 1000-2000-4000-8000 on request!

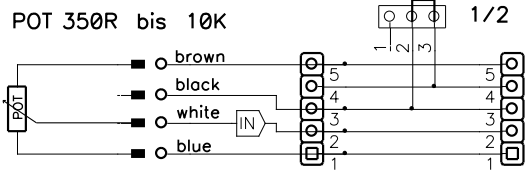



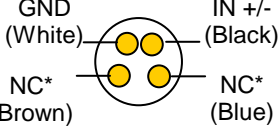

Connection CT-POT:

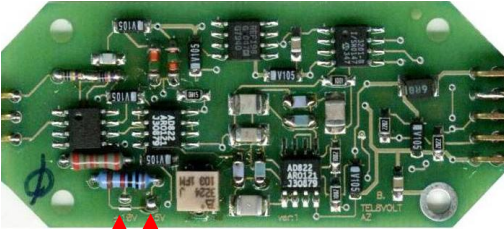
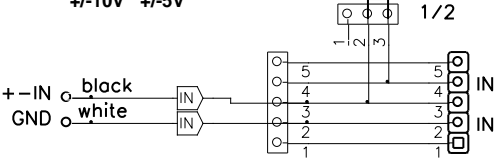
 <p>Sensor cable</p>	<p>Black = IN +/- White = GND Brown = +4V Blue = NC*</p> <p>*NC= not connected</p>	 <p>Sensor socket</p>	<p>CT-POT module for potentiometer sensors</p> <div style="display: flex; justify-content: space-around; align-items: center;"> <div style="text-align: center;">  </div> <div style="text-align: center;"> <p>Sensor plug CT2-Mini ENC</p>  </div> </div>
<p>CT-POT (=special type off STG) Type: Potentiometer >350Ohm to 1kOhm Excitation: 4 VDC (fixed) Accuracy +/- 0.25%</p> <p><u>Attention:</u> The POT modules must be configured as a Half Bridge Unit. <u>Don't change offset and gain!!</u></p>		 <p>Half bridge setting</p>	 <div style="text-align: center;"> <p>POT 350R bis 10K</p>  </div>





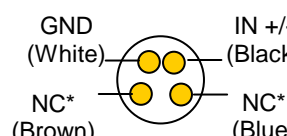

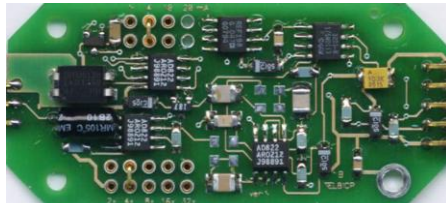
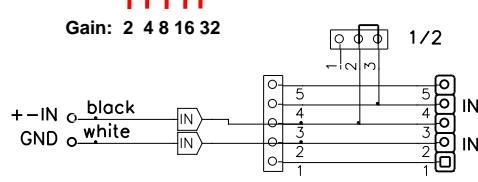
Connection CT-Volt module

 <p>Sensor cable</p>	<p>Black = IN +/- White = GND Brown = NC* Blue = NC*</p> <p>*NC= not connected</p>	 <p>Sensor socket</p>	<p>CT-Volt module</p> <div style="display: flex; justify-content: space-around; align-items: center;"> <div style="text-align: center;">  </div> <div style="text-align: center;"> <p>Sensor plug CT2-Mini ENC</p>  </div> </div>
<p>CT-Volt Type: Volt Range: +/-5 or +/-10V Accuracy +/- 0.25%</p> <p><u>Attentions:</u> At Volt modules must plug the plug bridge on Half Bridge Unit. <u>Don't change offset!!</u></p>		 <p>Half bridge setting</p>	 <div style="text-align: center;"> <p>+/-10V +/-5V</p>  </div>

Connection CT-ICP module

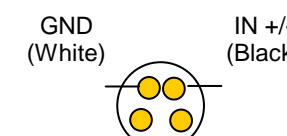

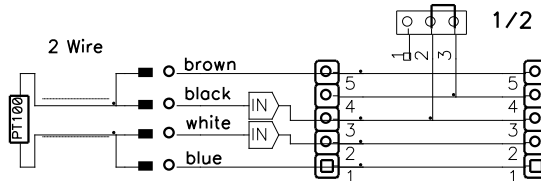

 <p style="text-align: center;">Sensor cable</p>	<p>Black = IN +/- White = GND Brown = NC* Blue = NC*</p> <p style="font-size: small;">*NC= not connected</p>	 <p style="text-align: center;">Sensor socket</p>	<div style="display: flex; align-items: center; justify-content: space-around;"> <div style="text-align: center;">  </div> <div style="text-align: center;"> <p>Sensor plug CT2-Mini ENC</p>  </div> </div>
<p>CT-ICP Type: ICP Gain: 2x, 4x, 8x, 16x or 32x Constant current: 1, 4 or 10mA Accuracy +/- 0.25%</p> <p><u>Attentions:</u> At ICP modules must plug the plugbridge on Half Bridge Unit.</p>		 <p style="text-align: center;">Half bridge setting</p>	<p style="text-align: center;">Current: 1 4 10</p>  <p style="text-align: center;">Gain: 2 4 8 16 32</p> 

Connection CT-Pt100 module (RTDs)

	<p>Black = IN White = GND Brown = NC* Blue = NC*</p> <p style="font-size: small;">*NC= not connected</p>		<div style="display: flex; align-items: center; justify-content: space-around;"> <div style="text-align: center;">  </div> <div style="text-align: center;">  </div> </div>
<p>CT-Pt100 Type: RTD 100 ohm Range: -100 to 500°C Accuracy +/- 0.25%</p> <p><u>Attentions:</u> At Pt100 modules must plug the plug bridge on Half Bridge Unit.</p>		 <p style="text-align: center;">Half bridge setting</p>	 

Temperature [°C]	Output [V]	Temperature [°C]	Output [V]	Temperature [°C]	Output [V]
-100	-0,997	150	1,501	400	4,004
-50	-0,497	200	2,001	450	4,498
0	0,001	250	2,501	500	4,999
50	0,499	300	3,001		
100	1,000	350	3,501		

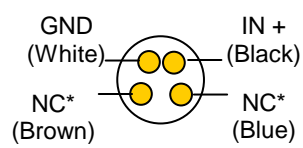
Connection TH-K ISO Thermo couple

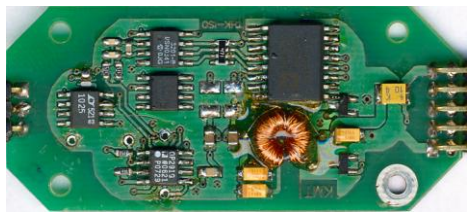
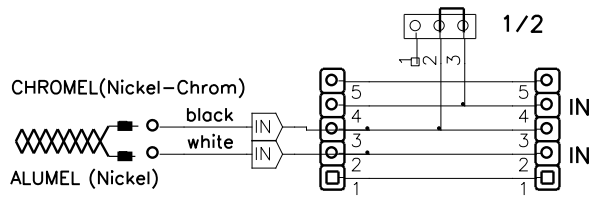
 <p style="text-align: center;">Sensor cable</p>	<p>Black = IN +/- White = GND Brown = NC* Blue = NC*</p> <p>*NC= not connected</p>	 <p style="text-align: center;">Sensor socket</p>	<div style="display: flex; justify-content: space-around; align-items: center;"> <div style="text-align: center;">  </div> <div style="text-align: center;"> <p>Sensor plug CT2-Mini ENC</p>  </div> </div>				
<p>CT-THK-ISO - Galvanic isolated!</p> <p>Type: K Range: -50°C – 1000°C Bandwidth: 0-20Hz (more on request) Accuracy +/-1%</p> <p><u>Attentions:</u> At Thermo couple must plug the plug bridge on Half Bridge Unit.</p>		 <p style="text-align: center;">Half bridge setting</p>	 <div style="text-align: center;">  </div>				
Temperature [°C]	Output [V]	Temperature [°C]	Output [V]	Temperature [°C]	Output [V]	Temperature [°C]	Output [V]
-50	-0.220	250	1.236	550	2.754	850	4.262
0	0.013	300	1.482	600	3.010	900	4.506
50	0.254	350	1.734	650	3.266	950	4.746
100	0.504	400	1.990	700	3.519	1000	4.980
150	0.752	450	2.242	750	3.700		
200	0.992	500	2.498	800	4.015		

Li Ion Re-Chargeable Battery with Charger Unit for CT-Wheel

Pin connection

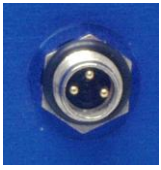

Charge plug at CT8-Wheel ENC

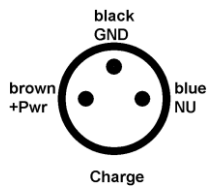

Battery charger CT8-Wheel

1. Plug the 3-pole socket (charger) in to the CT2-Wheel encoder.
2. Plug banana plugs on to a battery or AC/DC power supply with a voltage range of 10-30,
3. Press and hold the switch for 1 second to begin charging. The battery will now charge. Charge time 2-3 hours!

Mounting hole dimensions:

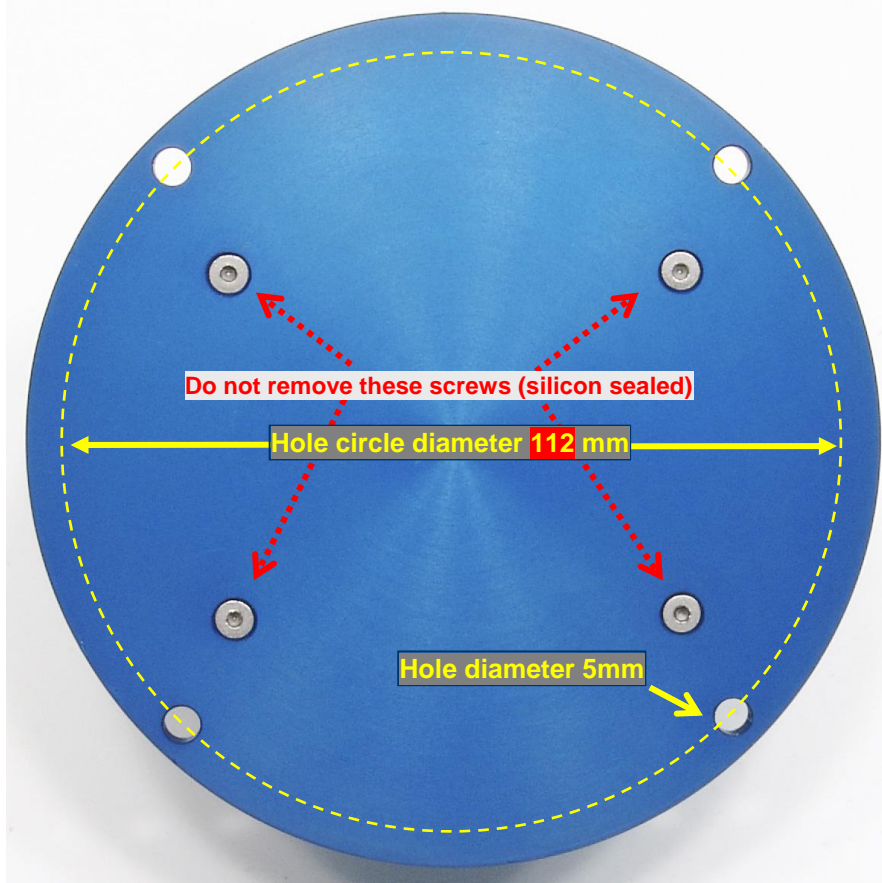

Base plate side

Dimensions CT2-Wheel-ENC:

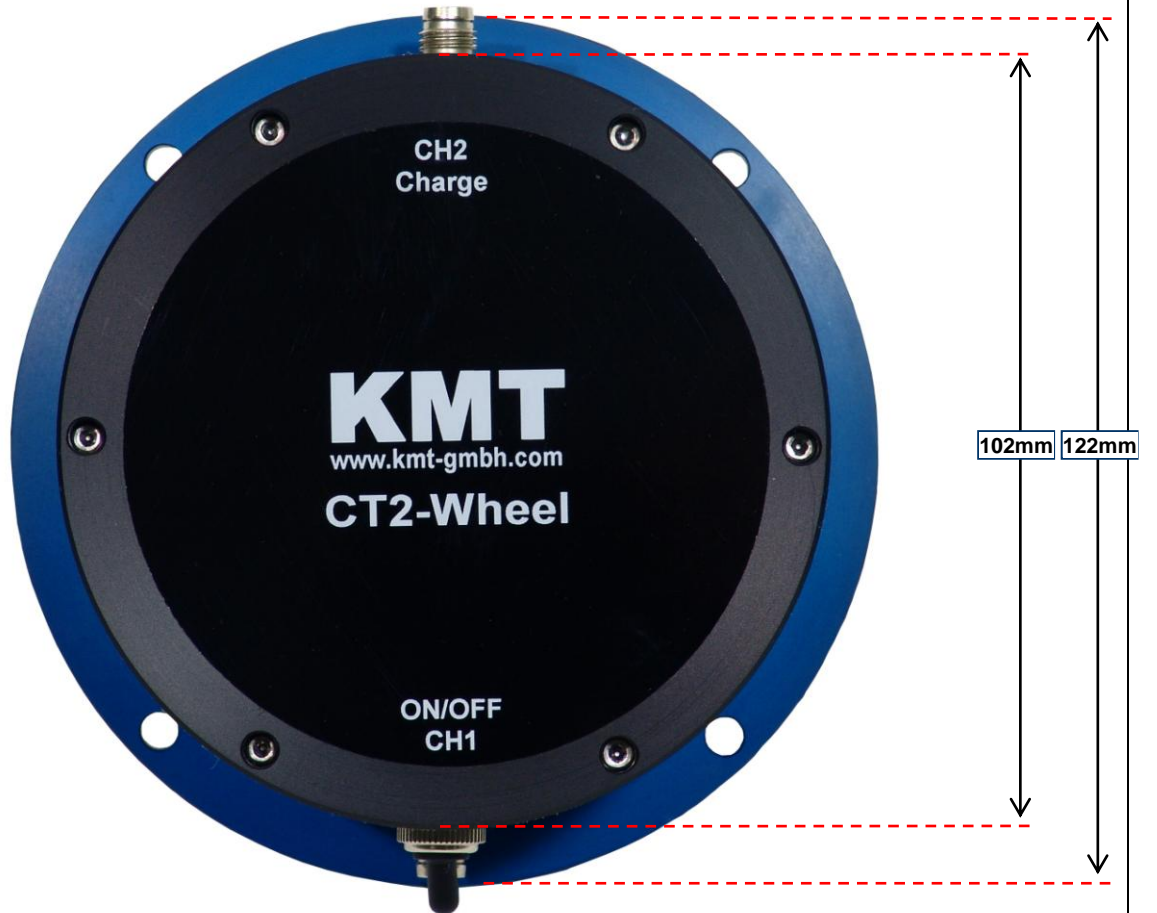

Placing of receiving antennas:



Kraus Messtechnik GmbH

Gewerbering 9, D-83624 Otterfing, ☎ +49-8024-48737, Fax. +49-8024-5532 – Germany
Home Page <http://www.kmt-gmbh.com> E-mail: info@kmt-gmbh.com



Konformitätserklärung

Declaration of Conformity
Declaration de Conformité

Wir
We
Nous

KMT - Kraus Messtechnik GmbH

Anschrift
Address
Adress

Gewerbering 9, D-83624 Otterfing, Germany

erklären in alleiniger Verantwortung, daß das Produkt
declare under our sole responsibility, that the product
declarons sous notre seule responsabilité, que le produit

Bezeichnung
Name
Nom

Messdatenübertragungssystem

Typ,Modell,Artikel-Nr., Größe
Type,Model, Article No.,Taille
Type, Modèle, Mo.d'Article,Taille

CT2-Wheel

mit den Anforderungen der Normen und Richtlinien
fulfills the requirements of the standard and regulations of the Directive
satisfait aux exigences des normes et directives

108/2004/EG

Elektromagnetische Verträglichkeit EMV / EMC

DIN EN 61000-6-3 Ausgabe 2002-8 Elektromagnetische Verträglichkeit
EMV Teil 6-3 Fachgrundnorm Störaussendung

DIN EN 61000-6-1 Ausgabe 2002-8 Elektromagnetische Verträglichkeit
EMV Teil 6-1 Fachgrundnorm Störfestigkeit

und den angezogenen Prüfberichten übereinstimmt und damit den Bestimmungen entspricht.
and the taken test reports and therefore corresponds to the regulations of the Directive
et les rapports d'essais notifiés et, ainsi, correspond aux règlement de la Directive.

Otterfing, 30.05.2006

Martin Kraus



Kraus Messtechnik GmbH
Gewerbering 9
D-83624 Otterfing - Germany
Tel. 08024-48737 - Fax 08024-5532
www.kmt-gmbh.com

Ort und Datum der Ausstellung
Place and Date of Issua
Lieu et date d'établissement

Name und Unterschrift des Befugten
Name and Signature of authorized person
Nom et signature de la personne autorisée

Version 20010-05

13

Technical Data are subject to change without notice!



www.instrumentation.it

INSTRUMENTATION DEVICES SRL

Via Acquanera 29, 22100 COMO (Italy) tel. +39.031.525391 - fax +39.031.507984 - info@instrumentation.it