



## e-corder 821 (Model ED821)



- Turns your PC or Macintosh into a precision data recorder
- No programming required – plug and play installation
- Powerful on-line and offline analysis
- Continuous recording up to 200 000 samples/s
- Independently selectable input gains  $\pm 2$  mV to  $\pm 10$  V
- 16 bit A/D resolution
- Bipolar output for pulse and waveform generation
- Trigger input TTL or contact closure
- USB 2.0 and 1.1 compliant

### Description

The **e-corder 821** is a high performance eight channel data recording and analysis system. It records analog data from a wide variety of transducers and instruments, along with eDAQ Amps and Pods. It features eight programmable input amplifiers, four of which can be configured for differential input. The system can record 16 bit resolution data directly to your PC at speeds of up to 200 000 samples/s via a USB 2.0 compliant interface. A built-in software controlled analog output, provides basic pulse and waveform generation.

### Computer System Compatibility

**e-corder** is compatible with the following computer environments.

Windows 2000 or XP or later. Systems with a minimum of 128 MB RAM and USB port.

MacOS X or later. Systems with minimum of 128 MB RAM and USB port.

### Applications

The **e-corder 821** is an ideal data recorder for use with multiple signal sources. Absolutely no programming is required and the powerful on-line and off-line analysis functions allow results to be quickly extracted from the recorded data. The system can be used to replace paper based chart recorders and data acquisition cards in applications such as Materials Testing, Engineering, Vibration Analysis, Sensor Research and Electrochemistry.

### Software

Chart™ and Scope™ software is shipped with every **e-corder** for both Windows and Macintosh.

Chart™ – lets you use your computer as a multichannel strip chart recorder, polygraph and digital voltmeter.

Scope™ – lets you use your computer as a two-channel storage oscilloscope, or XY plotter.

Specialist software and analysis extensions are also available for use with **e-corder** units.

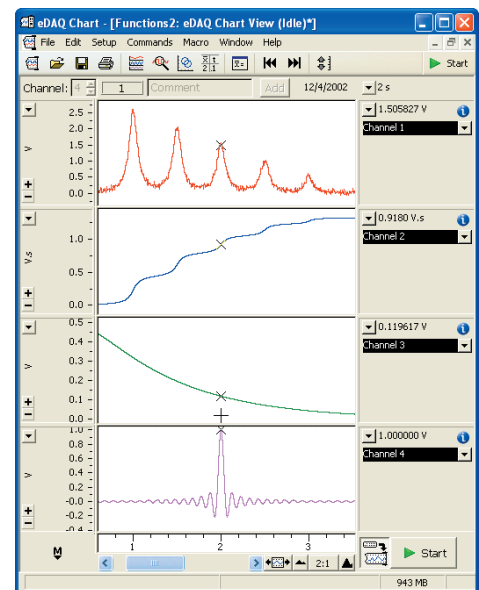
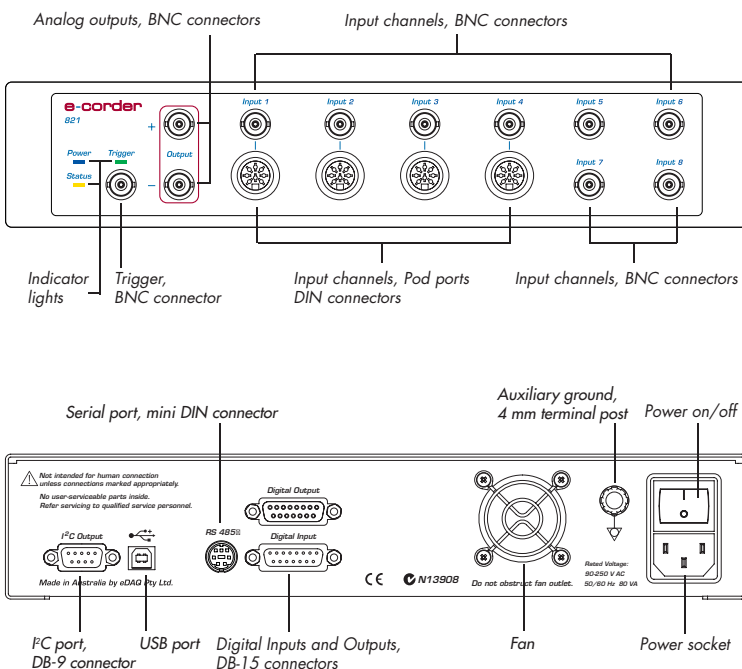

Main Chart window (Windows XP). All software has a user friendly interface and does not require additional programming to develop applications.

## Specifications

Analog Inputs			
Number of Input channels:	8		
Input configuration:	4 x single-ended BNC, or differential DIN 4 x single-ended BNC		
Amplification range:	±2 mV to ±10 V full scale in 12 steps		
	Range	Resolution (µV)	Gain
	±10 V	312.5	1
	±5 V	156.25	2
	±2 V	62.5	5
	±1 V	31.25	10
	±0.5 V	15.625	20
	±0.2 V	6.25	50
	±0.1 V	3.125	100
	±50 mV	1.56	200
	±20 mV	0.625	500
	±10 mV	0.3125	1000
	±5 mV	0.15625	2000
	±2 mV	0.0625	5000
Maximum input voltage:	±15 V		
Input impedance:	~1 MΩ    47 pF @ DC		
Low-pass filtering:	20 kHz fixed 2nd order (further filtering via software)		
AC coupling:	DC or 0.15 Hz (software-selectable)		
Frequency response (-3 dB):	25 kHz (100 mV – 10 V ranges) 10 kHz (5 mV – 50 mV ranges)		
DC drift:	Software corrected zero		
CMRR (differential):	>96 dB @100 Hz on 10 mV range		
Channel crosstalk:	> -82 dB (typical) between adjacent channels		
Input noise:	<2.4 µV <sub>rms</sub> + 250 µV <sub>rms</sub> /Gain RTI		
Pod Connectors			
Connector type:	8-pin DIN		
Supply voltage:	±5 V regulated		
Maximum current:	50 mA per Pod port		
Communications:	2 wire I <sup>2</sup> C		
Signal input:	Differential or single-ended analog inputs		
Sampling			
ADC resolution:	16 bit		
Linearity error:	±2 LSB (from 0 to 70 °C)		
Maximum sampling rates:	200 kHz for 1 – 2 channels 100 kHz for 3 – 4 channels 40 kHz for 5 – 8 channels		
Available sampling rates:	0.003 Hz to 200 kHz using Chart for Mac 2 Hz to 200 kHz using Scope 1 Hz to 200 kHz using Chart for Windows		
Output Amplifier			
Output configuration:	Bipolar or dual single-ended		
Output resolution:	16 bits		

Maximum output current:	2 x ±100 mA continuous	
Output impedance:	0.1 Ω typical	
Slew rate:	10 V/µs	
Settling time:	2 µs (to 0.1% of FSR)	
Output range:	±200 mV to ±10 V (software selectable)	
	Range (V)	Resolution (µV)
	±10	312.5
	±5	156.5
	±2	62.5
	±1	31.25
	±0.5	15.625
	±0.2	6.25
Output Zero error	<0.5 mV	
External Trigger		
Trigger mode:	TTL level or contact closure, software selectable	
Trigger threshold:	+1.3 V, 50 kΩ input impedance	
Hysteresis:	0.3 V	
Maximum input voltage:	±12 V	
Minimum detectable event:	5 µs	
Microprocessor and Data Communication		
CPU:	PowerPC 405 GPr (240 MHz)	
RAM:	16 MB DRAM	
ROM:	4 Mbit FLASH ROM	
Data communication:	USB 2.0 or 1.1 compliant (up to 480 Mbits/s)	
Expansion Ports		
I <sup>2</sup> C expansion port:	Power and control bus for eDAQ Amps (maximum of 500 mA). Interface communications rate of up to 10 000 bits/s.	
RS485 Serial Port	RS485 port for factory diagnostic purposes only.	
Digital input	8 independent, TTL input lines. 1.2 V threshold, 10 kΩ input impedance. 5 V maximum.	
Digital output	8 independent, TTL output level. 8 mA maximum load per line.	
Physical Configuration		
Dimensions (w x h x d):	300 x 60 x 300 mm (11.8" x 2.4" x 11.8")	
Weight:	4.8 kg (10 lb 8 oz)	
Operating voltage:	90 to 250 V AC 50/60 Hz	
Nominal power needs:	17 – 30 VA (dependant on number of eDAQ Amps and Pods attached).	
Operating conditions:	0 to 40 °C 0 to 90% humidity (non-condensing)	
<i>eDAQ Pty Ltd reserves the right to alter these specifications at any time.</i>		

WARRANTY: eDAQ Hardware units are supported by a one year warranty

[www.eDAQ.com](http://www.eDAQ.com)

E-mail: [info@edaq.com](mailto:info@edaq.com)

e-corder is a registered trademark of eDAQ Pty Ltd.  
All other trademarks are the property of their respective owners.

Document Number: M-ED821-0904

Copyright © eDAQ 2004