



SILICON DESIGNS, INC

Model 1221

LOW NOISE ANALOG ACCELEROMETER

- **SENSOR:** Capacitive Micromachined Nitrogen Damped Hermetically Sealed
- **Low Noise:** 5 $\mu\text{g}/\sqrt{\text{Hz}}$ typical for 2g Full Scale Version
- Internal Temperature Sensor
- $\pm 4\text{V}$ Differential Output or 0.5V to 4.5V Single Ended Output
- Fully Calibrated
- Responds to DC & AC Acceleration
- -55 to +125 °C Operation
- +5 VDC, 8 mA Power (typical)
- Non-Standard g Ranges Available
- Integrated Sensor & Amplifier
- LCC or J-Lead Surface Mount Package
- Serialized for Traceability
- Pin Compatible with Model 1210
- RoHS Compliant

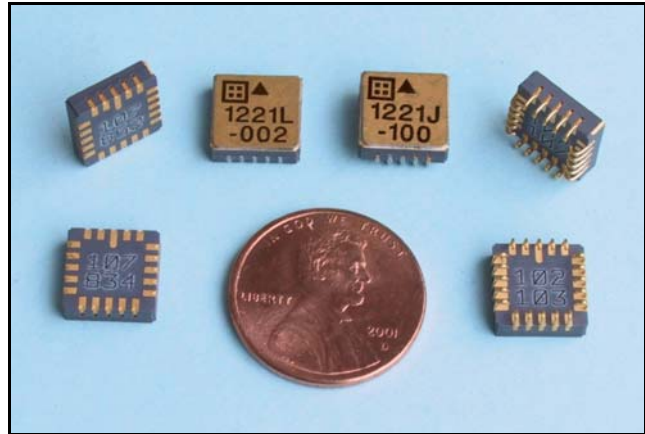

ORDERING INFORMATION

Full Scale Acceleration	Hermetic Packages	
	20 pin LCC	20 pin JLCC
± 2 g	1221L-002	1221J-002
± 5 g	1221L-005	1221J-005
± 10 g	1221L-010	1221J-010
± 25 g	1221L-025	1221J-025
± 50 g	1221L-050	1221J-050
± 100 g	1221L-100	1221J-100
± 200 g	1221L-200	1221J-200
± 400 g	1221L-400	1221J-400

DESCRIPTION

The Model 1221 is a low-cost, integrated accelerometer for use in zero to medium frequency instrumentation applications that require extremely low noise. The 2g version is ideally suited for seismic applications. Each miniature, hermetically sealed package combines a micro-machined capacitive sense element and a custom integrated circuit that includes a sense amplifier and differential output stage. It is relatively insensitive to temperature changes and gradients. Each device is marked with a serial number on its bottom surface for traceability. An optional calibration test sheet (1221-TST) is also available which lists the measured bias, scale factor, linearity, operating current and frequency response.

OPERATION

The Model 1221 produces two analog output voltages which vary with acceleration as shown in the figure below. The outputs can be used either in differential or single ended mode referenced to +2.5 volts. Two reference voltages, +5.0 and +2.5 volts (nominal), are required; the output scale factor is ratiometric to the +5 volt reference voltage, and both outputs at zero acceleration are equal to the +2.5 volt reference. The sensitive axis is perpendicular to the bottom of the package, with positive acceleration defined as a force pushing on the bottom of the package.

APPLICATIONS

- Seismic Monitoring
- Earthquake Detection
- Security Systems
- Machine Control
- Modal Analysis
- Instrumentation
- Appliances
- Robotics
- Crash Testing
- Vibration Monitoring
- Vibration Analysis
- Vehicle Dynamics

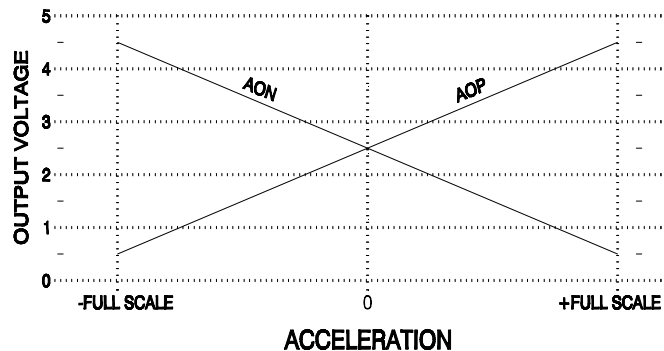



Model 1221 Low Noise Analog Accelerometer

SIGNAL DESCRIPTIONS

V_{DD} and GND (power): Pins (9,11,14) and (2,5,6,18,19) respectively. Power (+5 Volts DC) and ground.

AOP and AON (output): Pins 12 and 16 respectively. Analog output voltages proportional to acceleration. The AOP voltage increases (AON decreases) with positive acceleration; at zero acceleration both outputs are nominally equal to the +2.5 volt reference. The device experiences positive (+1g) acceleration with its lid facing up in the earth's gravitational field. Either output can be used individually or the two outputs can be used differentially but differential mode is recommended for both lowest noise and highest accuracy operation. Voltages can be measured ratiometrically to VR for good accuracy without requiring a precision reference voltage. (See plot.)

DV (input): Pin 4. Deflection Voltage. Normally left open. A test input that applies an electrostatic force to the sense element, simulating a positive acceleration. The nominal voltage at this pin is 1/2 V_{DD}. DV voltages higher than required to bring the output to positive full scale may cause device damage.

VR (input): Pin 3. Voltage Reference. Tie directly to V_{DD} for ratiometric measurements or to a +5V reference for better absolute accuracy. A 0.1µF bypass capacitor is recommended at this pin.

2.5 Volt (input): Pin 17. Voltage Reference. Tie to a resistive voltage divider from +5 volts or to a +2.5 volt reference voltage.

I_T (output): Pin 8. Temperature dependent current source. (May be tied to V_{DD}; see full description on page 5).

PERFORMANCE - by Model: V _{DD} =V _R =5.0 VDC, T _C =25°C.										
MODEL NUMBER	1221x-002	1221x-005	1221x-010	1221x-025	1221x-050	1221x-100	1221x-200	1221x-400	UNITS	
Input Range	±2	±5	±10	±25	±50	±100	±200	±400	g	
Frequency Response (Nominal, 3 dB)	0 - 400	0 - 600	0 - 1000	0 - 1500	0 - 2000	0 - 2500	0 - 3500	0 - 4000	Hz	
Sensitivity (Differential) ¹	2000	800	400	160	80	40	20	10	mV/g	
Output Noise (Differential, RMS, typical)	5	7	10	25	50	100	200	400	µg/(root Hz)	
Max. Mechanical Shock (0.1 ms)	2000		5000							g

Note 1: Single ended sensitivity is half of values shown.

PERFORMANCE - all Models: Unless otherwise specified V _{DD} =V _R =5.0 VDC, T _C =25°C, Differential Mode.					
PARAMETER	MIN	TYP	MAX	UNITS	
Cross Axis Sensitivity		2	3	%	
Bias Calibration Error ²	-002	2	4	% of span	
	-005 thru -200	1	2		
Bias Temperature Shift (T _C = -55 to +125°C) ²	-002	100	300	(ppm of span)/°C	
	-005 thru -200	50	200		
Scale Factor Calibration Error ^{2,3}		1	2	%	
Scale Factor Temperature Shift (T _C = -55 to +125°C) ²	-250		250	ppm/°C	
Non-Linearity (-90 to +90% of Full Scale) ^{2,3}	-002 thru -050	0.15	0.5	% of span	
	-100	0.25	1.0		
	-200	0.4	1.5		
	-400	0.7	2.0		
Power Supply Rejection Ratio		25		dB	
Output Impedance		90		Ohms	
Operating Voltage	4.75	5.0	5.25	Volts	
Operating Current (I _{DD} +I _{VR}) ²		8	10	mA	
Mass: 'L' package (add 0.06 grams for 'J' package)		0.62		grams	

Note 2: Tighter tolerances available on special order.

Note 3: 100g and greater versions are tested from -65 to +65g.

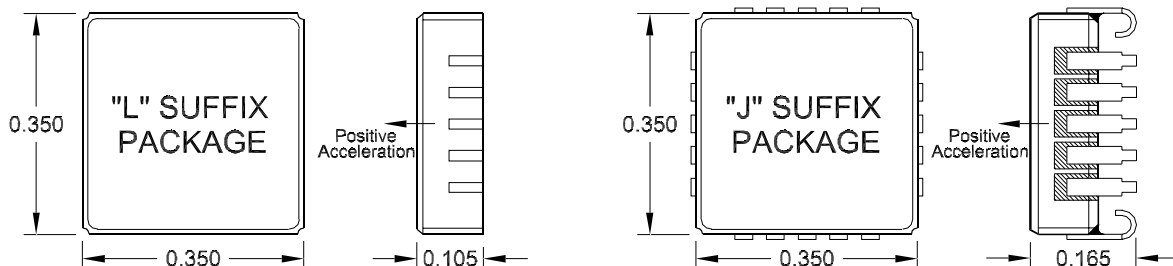

SPECIFICATIONS SUBJECT TO CHANGE WITHOUT NOTICE



Model 1221 Low Noise Analog Accelerometer

ABSOLUTE MAXIMUM RATINGS *

Case Operating Temperature	-55 to +125°C
Storage Temperature	-55 to +125°C
Acceleration Over-range	2000g for 0.1 ms
Voltage on V _{DD} to GND	-0.5V to 6.5V
Voltage on Any Pin (except DV) to GND ⁴	-0.5V to V _{DD} +0.5V
Voltage on DV to GND ⁵	±15V
Power Dissipation	50 mW

Note 4: Voltages on pins other than DV, GND or V_{DD} may exceed 0.5 volt above or below the supply voltages provided the current is limited to 1 mA..

Note 5: The application of DV voltages higher than required to bring the output to positive full scale may cause device damage.

*** NOTICE:** Stresses greater than those listed above may cause permanent damage to the device. These are stress ratings only. Functional operation of the device at or above these conditions is not implied. Exposure to absolute maximum rating conditions for extended periods may affect device reliability.

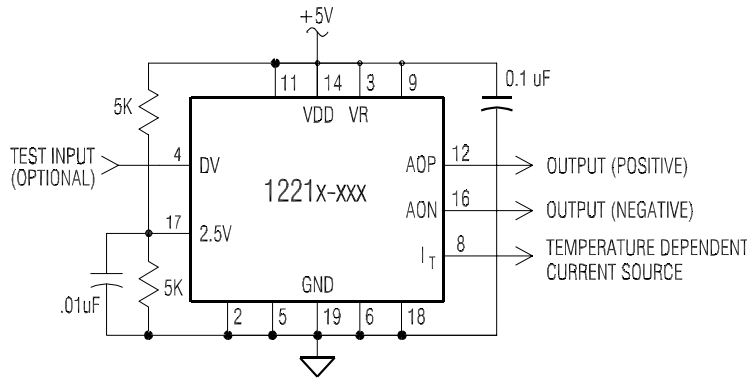

RECOMMENDED CONNECTIONS

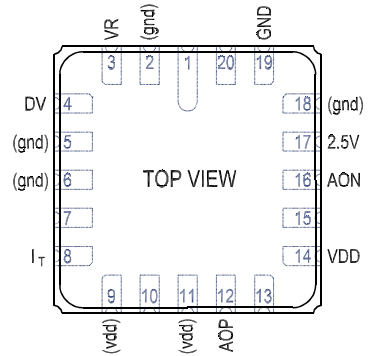

**PINOUT
(LCC & JLCC PACKAGES)**

The 2.5V reference input (pin 17) may be driven from either a precision voltage source or by the capacitively bypassed resistive divider shown above.

DEFLECTION VOLTAGE (DV) TEST INPUT: This test input applies an electrostatic force to the sense element, simulating a positive acceleration. It has a nominal input impedance of 32 kΩ and a nominal open circuit voltage of 1/2 V_{DD}. For best accuracy during normal operation, this input should be left unconnected or connected to a voltage source equal to 1/2 of the V_{DD} supply. The change in differential output voltage (AOP - AON) is proportional to the square of the difference between the voltage applied to the DV input (V_{DV}) and 1/2 V_{DD}. Only positive shifts in the output voltage may be generated by applying voltage to the DV input. When voltage is applied to the DV input, it should be applied gradually. The application of DV voltages greater than required to bring the output to positive full scale may cause device damage. The proportionality constant (k) varies for each device and is not characterized.

$$\Delta(AOP - AON) \approx k(V_{DV} - \frac{1}{2}V_{DD})^2$$

ESD and LATCH-UP CONSIDERATIONS: The model 1221 accelerometer is a CMOS device subject to damage from large electrostatic discharges. Diode protection is provided on the inputs and outputs but care should be exercised during handling to assure that the device is placed only on a grounded conductive surface. Individuals and tools should be grounded before coming in contact with the device. Do not insert the model 1221 into (or remove it from) a powered socket.

SPECIFICATIONS SUBJECT TO CHANGE WITHOUT NOTICE



Model 1221 Low Noise Analog Accelerometer

INTERNAL TEMPERATURE SENSING

The model 1221 accelerometer contains a temperature dependent current source that is output on pin 8. This signal is useful for measuring the internal temperature of the accelerometer so that any previously characterized bias and scale factor temperature dependence, for a particular accelerometer, can be corrected. The nominal output current at 25°C is ≈500 μA and the nominal sensitivity is 1.5 μA/°C. It is up to the user to characterize each device’s exact output current versus temperature over the range it is to be used. Fluctuations in V_{DD} & V_R have little effect on the temperature reading. A reduction of 0.10 V to both V_{DD} & V_R will reduce the current about 1 μA which corresponds to less than a 1°C change in reading.

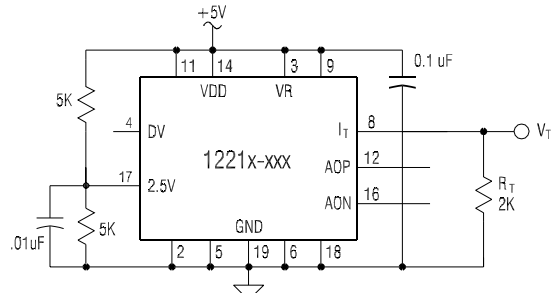

FIGURE 1

With a single resistor R_T = 2K between I_T (pin 8) and GND, as shown in Figure 1, the output voltage V_T will vary between +0.76 and +1.3 volts from -55 to +125°C, which equates to a sensitivity of ≈+3 mV/°C.

$$V_T \approx R_T \left[(500\mu A) + [(1.5\mu A)(T - 25)] \right] \qquad \frac{\Delta V_T}{\Delta T} = R_T (1.5\mu A)$$

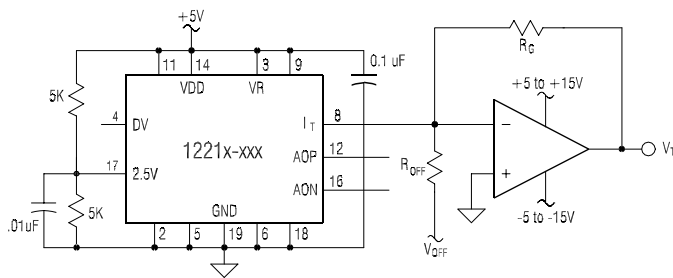

FIGURE 2

If a greater voltage change versus temperature or a lower signal source impedance is needed, the circuit in Figure 2 can be used. With offset voltage V_{OFF} = -5V, gain resistor R_G = 15.0K and offset resistor R_{OFF} = 7.32K, the output voltage V_T will vary between +4.5 and +0.5 Volts from -55 to +125°C, which equates to a sensitivity of ≈ -29 mV/°C.

$$V_T \approx -R_G \left[\frac{V_{OFF}}{R_{OFF}} + (500\mu A) + [(1.5\mu A)(T - 25)] \right]$$

$$R_{OFF} = \frac{-V_{OFF}}{\left(\frac{V_T}{R_G} \right) + (500\mu A) + [(1.5\mu A)(T - 25)]}$$

$$R_G = \frac{-\Delta V_T}{(1.5\mu A)(\Delta T)}$$

$$\frac{\Delta V_T}{\Delta T} = -R_G (1.5\mu A)$$

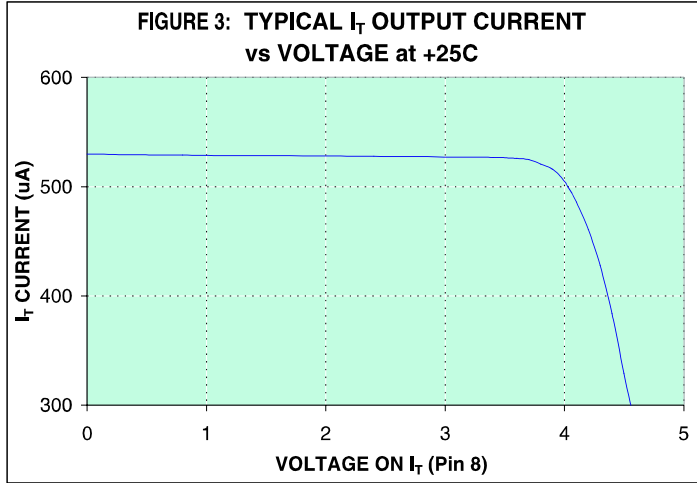

Figure 3 shows the voltage compliance of the temperature dependent current source (I_T) at room temperature. The voltage at pin 8 must be kept in the 0 to +3V range in order to achieve proper temperature readings.

SPECIFICATIONS SUBJECT TO CHANGE WITHOUT NOTICE



Model 1221 Low Noise Analog Accelerometer

BIAS STABILITY CONSIDERATIONS

Bias temperature hysteresis can be minimized by temperature cycling your model 1221 accelerometer after it has been soldered to your circuit board. If possible, the assembled device should be exposed to ten cycles from -40 to +85 °C minimum (-55 to +125 °C recommended). The orientation to the Earth's gravitational field during temperature cycling should preferably be in the same orientation as it will be in the final application. The accelerometer does not need to have power applied during this temperature cycling.

PACKAGE DIMENSIONS

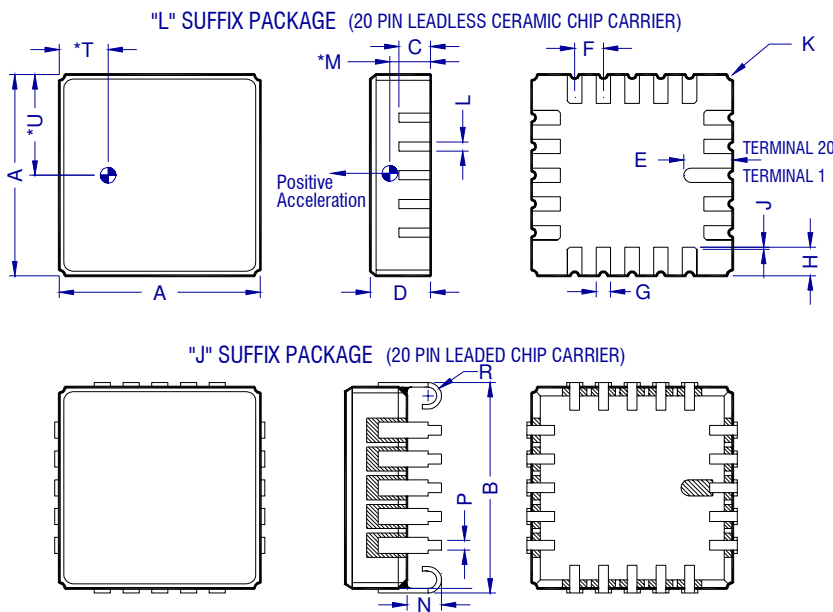

DIM	INCHES		MILLIMETERS	
	MIN	MAX	MIN	MAX
A	0.342	0.358	8.69	9.09
B	0.346	0.378	8.79	9.60
C	0.055 TYP		1.40 TYP	
D	0.095	0.115	2.41	2.92
E	0.085 TYP		2.16 TYP	
F	0.050 BSC		1.27 BSC	
G	0.025 TYP		0.64 TYP	
H	0.050 TYP		1.27 TYP	
J	0.004 x 45°		0.10 x 45°	
K	0.010 R TYP		0.25 R TYP	
L	0.016 TYP		0.41 TYP	
* M	0.048 TYP		1.23 TYP	
N	0.050	0.070	1.27	1.78
P	0.017 TYP		0.43 TYP	
R	0.023 R TYP		0.58 R TYP	
* T	0.085 TYP		2.16 TYP	
* U	0.175 TYP		4.45 TYP	

- NOTES: 1. * DIMENSIONS 'M', 'T' & 'U' LOCATE ACCELERATION SENSING ELEMENT'S CENTER OF MASS .
 2. LID IS ELECTRICALLY TIED TO TERMINAL 19 (GND).
 3. CONTROLLING DIMENSION: INCH.
 4. TERMINALS ARE PLATED WITH 60 MICRO INCHES MIN GOLD OVER 80 MICRO INCHES MIN NICKEL. (THIS PLATING SPECIFICATION DOES NOT APPLY TO THE METALLIZED PIN IDENTIFIER MARK ON THE BOTTOM OF THE J LEAD VERSION OF THE PACKAGE).
 5. PACKAGE: 90% MINIMUM ALUMINA (BLACK), LID: SOLDER SEALED KOVAR.

SOLDERING RECOMMENDATIONS:

RoHS Compliance: The model 1221 does not contain elemental lead and is RoHS compliant.

WARNING: If no-lead solder is to be used to attach the device, we do not recommend the use of reflow soldering methods such as vapor phase, solder wave or hot plate. These methods impart too much heat for too long of a period of time and may cause excessive bias shifts. For no-lead soldering, we only recommend the manual "Solder Iron Attach" method (listed on the next page of this data sheet). We also do not recommend the use of ultrasonic bath cleaners because these models contain internal gold wires that are thermo sonically bonded.



Model 1221 Low Noise Analog Accelerometer

SOLDERING RECOMMENDATIONS (continued):

Reflow of Sn62 or Sn63 type solder using a hotplate is the preferred method for assembling the model 1221 surface mount accelerometer to your Printed circuit board. Hand soldering using a fine tipped soldering iron is possible but difficult without a steady hand and some form of visual magnification due to the small size of the connections. When using the hand solder iron method, it's best to purchase the J-Leaded version (1221J) for easier visual inspection of the finished solder joints.

Pre-Tinning of Accelerometer Leads is Recommended: To prevent gold migration embrittlement of the solder joints, it is best to pre-tin the accelerometer leads. We recommend tinning one lead at a time, to prevent excessive heating of the accelerometer, using a fine-tipped solder iron and solder wire. The solder bath method of pre-tinning is not recommended due to the high degree of heat the interior of the device gets subjected to which may cause permanent shifts in the bias and/or scale factor.

Hotplate Attach Method using Solder Paste or Solder Wire: Apply solder to the circuit board's pads using Sn62 or Sn63 solder paste or pre-tin the pads using solder and a fine tipped soldering iron. If pre-tinning with an iron, apply flux to the tinned pads prior to placing the components. Place the accelerometer in its proper position onto the pasted or tinned pads then place the entire assembly onto a hotplate that has been pre-heated to 250°C. Leave on hotplate only long enough for the solder to flow on all pads (**DO NOT OVERHEAT!**)

Solder Iron Attach Method using Solder Paste: Apply solder paste to the circuit board's pads where the accelerometer will be attached. Place the accelerometer in its proper position onto the pasted pads. Press gently on the top of the accelerometer with an appropriate tool to keep it from moving and heat one of the corner pads, then an opposite corner pad with the soldering iron. Make sure the accelerometer is positioned so all 20 of its connections are centered on the board's pads. Once the two opposite corner pads are soldered, the part is secure to the board and you can work your way around soldering the remaining 18 connections. Allow the accelerometer to cool in between soldering each pin to prevent overheating.

Solder Iron Attach Method using Solder Wire: Solder pre-tin two opposite corner pads on the circuit board where the accelerometer will be attached. Place the accelerometer in its proper position onto the board. Press gently on the top of the accelerometer and heat one of the corner pads that was tinned and the part will drop down through the solder and seat on the board. Do the same at the opposite corner pad that was tinned. Make sure the accelerometer is positioned so all 20 of its connections are centered on the board's pads. Once the two opposite corner pads are soldered, the part is secure to the board and you can work your way around soldering the remaining 18 connections. Allow the accelerometer to cool in between soldering each pin to prevent overheating.

LCC & JLCC Solder Contact Plating Information: The plating composition and thickness for the solder pads and castellations on the "L" suffix (LCC) package are 60 to 225 micro-inches thick of gold (Au) over 80 to 350 micro-inches thick of nickel (Ni) over a minimum of 5 micro-inches thick of moly-manganese or tungsten refractory material. The leads for the "J" suffix (JLCC) package are made of an Iron-Nickel sealing alloy and have the same gold over nickel plating thicknesses as for the LCC pads.

Recommended Solder Pad Pattern: The recommended solder pad size and shape for both the LCC and J-LCC packages is shown in the diagram and table below. These dimensions are recommendations only and may or may not be optimum for your particular soldering process.

DIM	inch	mm
A	.230	5.84
B	.430	10.92
C	.100	2.54
D	.033	0.84
E	.050	1.27
F	.013	0.33
G	.120	3.05

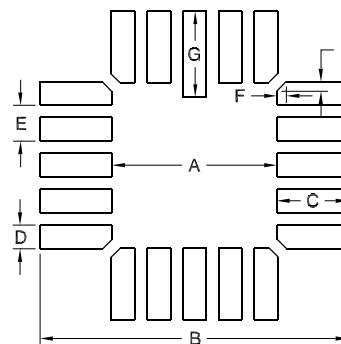



APPLICATION NOTE

Model 1221 Analog Accelerometer

ADDING A SINGLE ENDED OUTPUT TO THE MODEL 1221 DIFFERENTIAL OUTPUT ACCELEROMETER

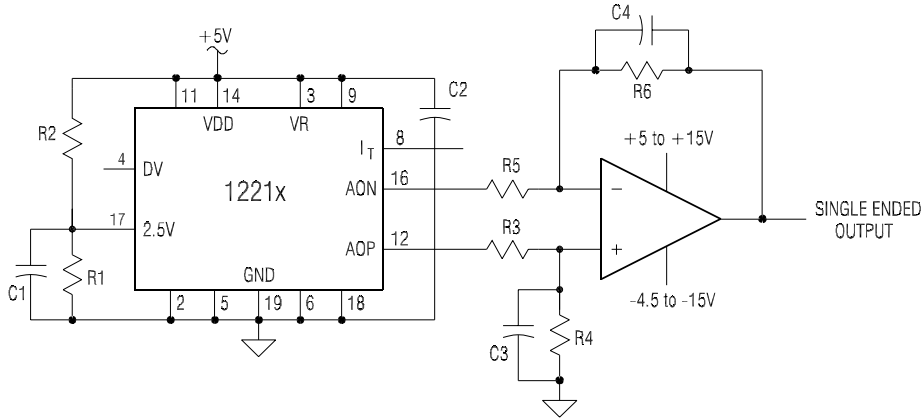

R1 = R2 = 5.00K ±0.5% for precision 2.50V ref.	R3, R4, R5 & R6 = 20kΩ to 50kΩ R3 = R5 to within 0.1% for common mode rejection R4 = R6 to within 0.1% for common mode rejection R4 / R3 ratio accurate to within 0.1% for gain control R6 / R5 ratio accurate to within 0.1% for gain control
C1 = C2 (See below for value calculation)	

To achieve the highest resolution and lowest noise performance from your model 1221 accelerometer module, it should be connected to your voltage measurement instrument in a differential configuration using both the **AOP** and **AON** output signals. If your measurement instrument lacks differential input capability or you desire to use a differential input capable instrument in single ended mode, then the circuit above can be used to preserve the low noise performance of the model 1221 while using a single ended type connection.

This circuit converts the ± 4 Volt differential output of the model 1221 accelerometer, centered at +2.5 Volts, to a single ended output centered about ground (0.0 Volts). It provides the advantage of low common mode noise by preventing the accelerometer's ground current from causing an error in the voltage reading.

The op-amp should be located as close as possible to your voltage monitoring equipment so that the majority of the signal path is differential. Any noise present along the differential path will affect both wires to the same degree and the op-amp will reject this noise because it is a common mode signal. The op-amp type is not critical; a μA741 or ¼ of a LM124 can be used. Both plus and minus supplies are needed for the op-amp to accommodate the positive and negative swings of the single ended output. The same +5V supply can be used for both the op-amp and the 1221 or a higher voltage positive supply can be used for the op-amp if you need a larger single ended output swing.

For this design, always set R₄ = R₆, R₃ = R₅ and C₃ = C₄. The gain of the circuit is then determined by the ratio R₄/R₃. When R₄ = R₃ = R₆ = R₅, the gain equals 1 and the output swing will be ± 4 Volts single ended with respect to ground. To obtain a ± 5 Volt single ended output, set R₄/R₃ = R₆/R₅ = 5/4 = 1.25. The single ended output of the op-amp will be centered at ground if R₄ and C₃ are tied to ground; using some other fixed voltage for this reference will shift the output. The value of the optional capacitors C₃ and C₄ (C₃ = C₄) can be selected to roll off the frequency response to the frequency range of interest. The cutoff frequency f₀ (-3 dB frequency) for this single order low pass filter is given by:

$$f_0 = \frac{1}{2\pi R_4 C_3}$$