

ZOC 17

Temperature Compensated Electronic Pressure Scanning Module

INSTRUCTION and SERVICE MANUAL

11/2012

1722 North Madson Street
Liberty Lake, WA 99019
Tel: (800) 935-5151
(509) 891-9970
Fax: (509) 891-9481
web site: www.scanivalve.com
e-mail: scanco@scanivalve.com



Questi prodotti sono distribuiti e supportati in Italia da:



Instrumentation Devices Srl

Via Acquanera 29 - 22100 COMO (Italy)
ph +39 031 525 391- fax +39 031 507 984
info@instrumentation.it - www.instrumentation.it

TABLE OF CONTENTS

SPECIFICATIONS.	<u>3</u>
GENERAL DESCRIPTION.	<u>5</u>
ZOC17/8Px - MUXLESS.	<u>6</u>
ZOC17/8Px - APC(Amplifier per Channel)..	<u>7</u>
ZOC17/16Px - MULTIPLEXED.	<u>8</u>
ZOC17/8DPx - TRUE DIFFERENTIAL.	<u>9</u>
ISOLATE-PURGE VALVES.	<u>10</u>
Isolate-Purge Mode Procedure.	<u>10</u>
THERMAL CONTROL UNIT.	<u>12</u>
OPERATION AND INSTALLATION.	<u>15</u>
Excitation Board.	<u>16</u>
Transition Board.	<u>17</u>
Amplifier per Channel Board.	<u>18</u>
Multiplexer/Amplifier Board.	<u>21</u>
Electrical Inputs and Outputs.	<u>24</u>
Pneumatic Inputs.	<u>26</u>
SENSOR INSTALLATION.	<u>27</u>

FIGURES

1 - ZOC17/8Px-Muxless Module.	6
2 - ZOC17/8Px-APC Module.	7
3 - ZOC17/16Px Module.	8
4 - ZOC17/8DPx - True Differential Module.	9
5 - Control Pressure Truth Table.	10
6 - ZOC17 8 Channel Block.	11
7 - Typical ZOC17 Thermal Control Unit (TCU).	12
8 - ZOC17 TCU Pneumatic Connections.	13
9 - ZOC TCU Pneumatic Connector.	14
10 - ZOC TCU Electrical Connections.	14
11 - Excitation Board Schematic.	16
12 - ZOC17/8Px Transition Board.	17
13 - Amplifier per Channel Board Layout.	18
14 - APC Board Electrical Schematic, Part 1.	19
15 - APC Board Electrical Schematic, Part 2.	20
16 - ZOC17 Mux-Amp Board.	21
17 - Mux/Amp Board Schematic.	22
18 - Analog/Address Bus Schematic.	23
19 - ZOC17/8Px Output Connector.	25
20 - ZOC17/APC Output Connector.	25
21 - ZOC17/16Px Output Connector.	25
22 - ISO-Purge Valve Logic.	27
23 - ZOC17 Sensor Replacement.	28
24 - ZOC Temperature Compensated Sensor.	30
25 - Identification Labels - ZOC Temperature Compensated Sensors.	31

SPECIFICATIONS

Inputs (Px)	8 (Muxless, APC, DeltaP) or 16 (Muxed)	
Full Scale Ranges	10 inch H ₂ O(2.5 kPa) 1,2.5,5,15,50,100,250, 500, 600, 750 and 850 psid (7,17,35,103,345,690,1724,3447,4135, 5171, and 5861 kPa)	
Accuracy(% Full Scale)	10 inch H ₂ O(2.5 kPa)	= ±0.20% F.S.
	1 psid (7 kPa)	= ±0.15% F.S.
	2.5psid (17kPa)	= ±0.10% F.S.
	3 - 500 psid (21 - 3500 kPa)	= ±0.08% F.S
	600 - 750 psid (4150 - 5250 kPa)	= ±0.12% F.S
Sensor Excitation	1.5mA Constant Current	
Full Scale Output	Muxless - 40 to 100mV ±3mV (Each Sensor) Muxed - 2.5Vdc (Addressed channel) APC - 2.5Vdc per channel(nominal) - 3.0Vdc or 5.0Vdc optional	
Operating Temp	0 to 70° C Standard (0 to 125° C optional)	
Compensated Range	0 to 50° C	
Temp. Sensitivity	Zero 0.009%FS/° C Span 0.007%FS/° C	
Overpressure (No Damage)	1 psid (7 kPa)	- 5 psi (35 kPa)
	2.5 - 100 psid (17 - 700 kPa)	- 4xFS
	200 psid (1400 kPa)	- 600 psi (4200 kPa)
	500 psid (3500 kPa)	- 750 psi (5250 kPa)
	750 psid (5250 kPa)	- 750 psi (5250 kPa)
Max Ref Press	10 inch H ₂ O - 5 psid (35kPa)	- 40 psia (275 kPa)
	5 psid - 50 psid (35 - 350kPa)	- 100 psia (700 kPa)
	>50 psid (350 kPa)	- 250 psia (1725 kPa)
Media	Gases compatible with Silicon, Silicone, Aluminum, and Buna-N	

Connector Type	Muxless	- 21 pin MDM 21SL2P
	Muxed	- 15 pin MDM 15SL2P
	APC	- DB25P
Power Requirements	Muxless	- $\pm 15\text{Vdc}$ @ 25 mA
	APC	- $\pm 15\text{Vdc}$ @ 200 mA
	Muxed	- $\pm 15\text{Vdc}$ @ 100 mA
Weight	Muxless	- 1.5 lbs.(680g)
	APC	- 1.75 lbs.(795g)
	Muxed	- 3.0 lbs.(1.36kg)
Accessories	Mating Connectors furnished	

GENERAL DESCRIPTION

The ZOC®17 is an electronic pressure scanner which can accept up to 16 pneumatic inputs. Each ZOC17 module incorporates up to 16 individual temperature compensated, piezoresistive pressure sensors. Each pressure sensor is manufactured in a housing designed to facilitate field replacement. No special tools are required to access the sensors. The ZOC17 electronic pressure scanning module is specifically designed for use in applications where long calibration intervals are required or temperatures can vary greatly. The ZOC17 pressure sensors are temperature compensated from 0 to 50°C. A constant current source is used for sensor excitation to further improve sensor stability.

The ZOC17 sensors are arranged in blocks of eight(8). Each block of eight sensors has its own individual calibration valve. This valve has four modes of operation:

- (1) Operate
- (2) Calibrate
- (3) Purge
- (4) Isolate

The modes are selected by applying control pressures in a predetermined logical order. The ZOC17 calibration valve utilizes "Normally Px" valve logic where the valve defaults to the operate mode when no control pressures are applied.

The ZOC17 is powered by $\pm 15\text{Vdc}$. The module is manufactured in a 16 channel multiplexed model and an 8 channel muxless model. The multiplexed version is designed to function best with the HyScan® 1000 or HyScan 2000 High Speed Data Acquisition Systems. Both versions may be used in customer designed data acquisition systems or in a "stand alone" configuration. Both versions are available with an optional Isolate-Purge valve.

ZOC17/8Px - MUXLESS

This module contains eight sensors, a calibration valve, an excitation board, and an interface board. The output of each sensor is connected directly to the interface connector. All sensor outputs are within a range of 30 to 150 mVdc depending upon the pressure range. In any one module the sensors will be grouped so that all outputs are within ± 20 mVdc of one another. All sensor zero offsets are normalized to ± 3 mVdc.

Figure 1 shows the ZOC 17/8Px-Muxless Module.

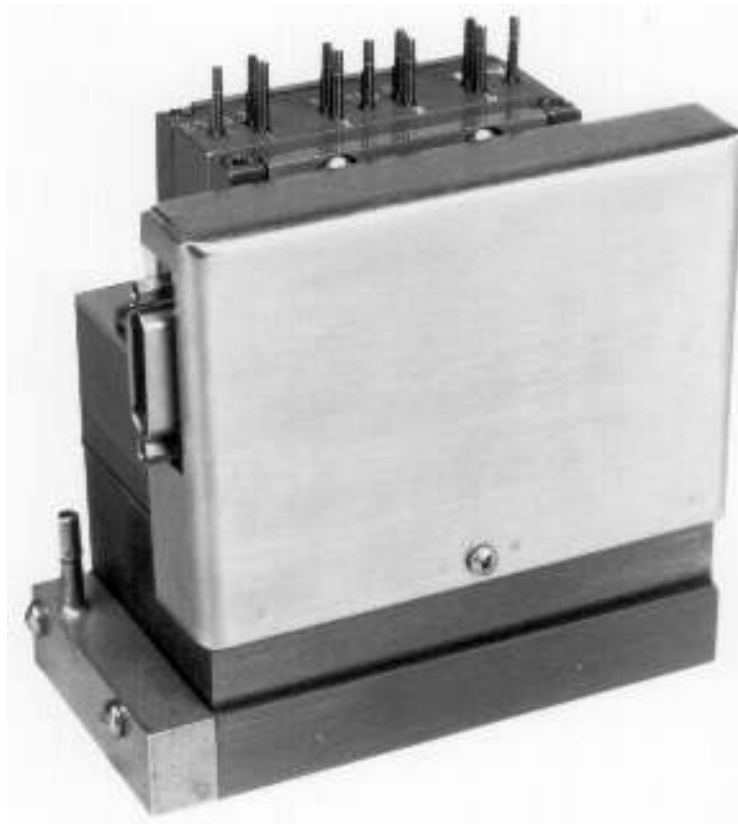

Figure 1 - ZOC17/8Px-Muxless Module

ZOC17/8Px - APC(Amplifier per Channel)

This module is a variation of the ZOC17/8Px- Muxless Module. It contains 8 sensors, a calibration valve, an excitation board, and an amplifier/interface board. The output of each sensor is connected directly to the amplifier/interface board where the signal is amplified to a nominal $\pm 2.5\text{Vdc}$. All sensor outputs are within a range of 2.2 to 2.8Vdc depending upon the pressure range and the output of the individual sensor. (In any one module the sensors will be grouped so that all unamplified outputs are within $\pm 20\text{ mVdc}$ of one another.) All sensor zero offsets are normalized to $\pm 3\text{ mVdc}$. The gain of each module is fixed at the factory when the module is manufactured. All channels in a module will have the same gain but not the same output. This module is also available with nominal outputs of $\pm 3.0\text{Vdc}$ or $\pm 5.0\text{Vdc}$.

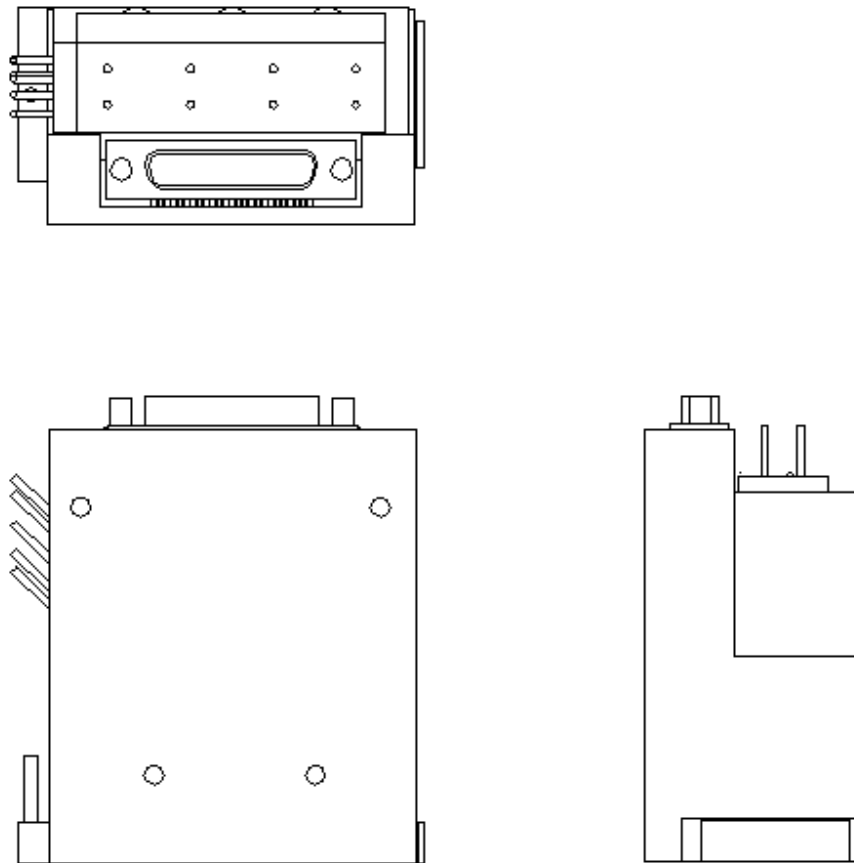

Figure 2 - ZOC17/8Px-APC Module

ZOC17/16Px - MULTIPLEXED

This module contains 16 sensors, two calibration valves, an excitation board, and a multiplexer/amplifier. The sensors are arranged in two groups of eight. Each group of eight sensors may be a different range. The output of the pressure sensors are amplified to a nominal $\pm 2.5\text{Vdc}$ corresponding to the channel selected by a 4 bit binary address.

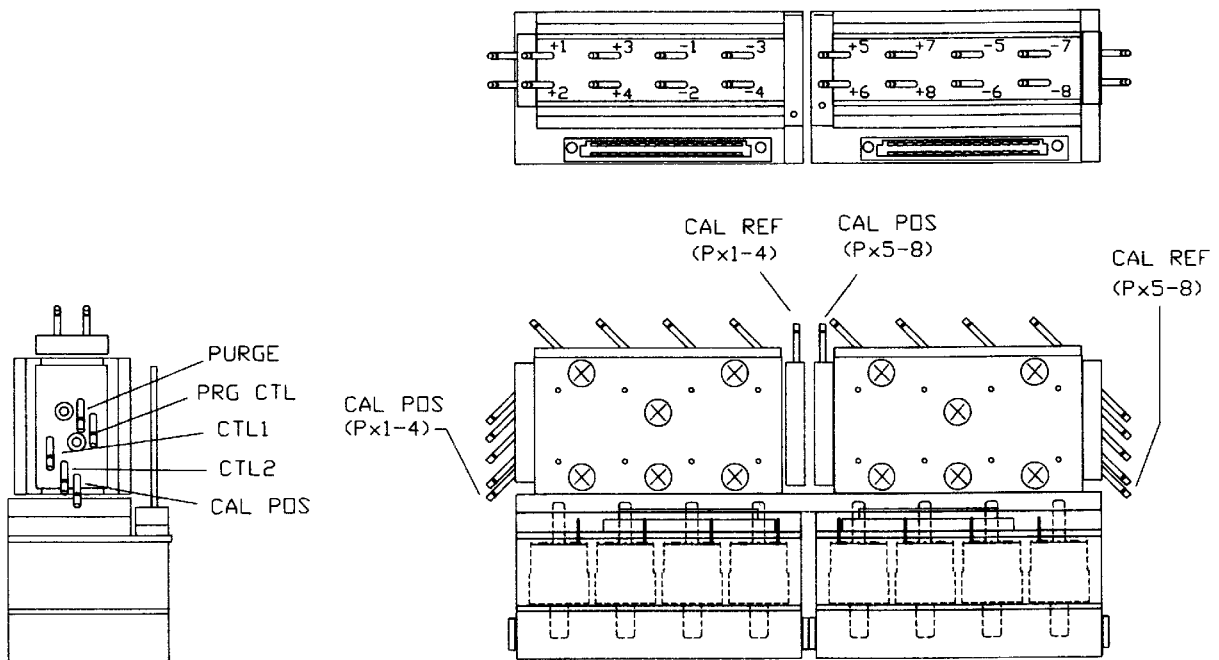

Figure 3 - ZOC17/16Px Module

ZOC17/8DPx - TRUE DIFFERENTIAL

This module contains 8 sensors, two calibration valves, an excitation board, and a multiplexer/amplifier. The sensors are arranged in two groups of four sensors. Each group of four sensors may be a different range. The output of the pressure sensors are amplified to a nominal $\pm 2.5\text{Vdc}$ corresponding to the channel selected by a 4 bit binary address. This module has a modified setup such that each sensor has its own reference input. This permits the measurement of true differential pressures.

Figure 4 shows a ZOC17/8DPx Module. The broken lines show the pressure path for the reference inputs. The transducers with the through paths are "dummy" transducers. Only four transducers are shown for clarity.

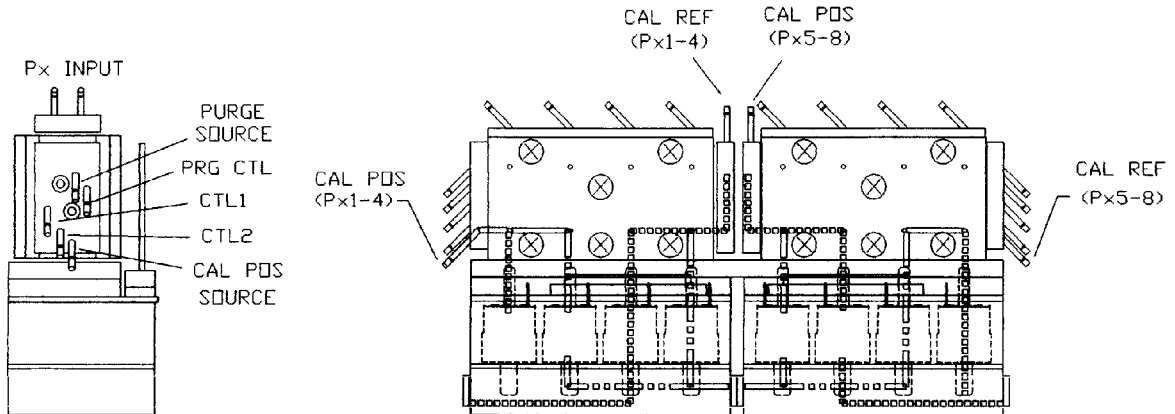

Figure 4 - ZOC17/8DPx - True Differential Module

ISOLATE-PURGE VALVES

The Isolate-Purge option adds another set of valving which permits the input lines to be purged at pressures up to 750psi. This option permits the safe use of a high pressure purge of low pressure inputs. This is especially useful when the ZOC17 modules are used in applications where corrosive gases may be present in the input lines.

Figure 5 is a table which shows the pressure requirements for each mode of the ZOC17 valves. The basic modes are quite simple to set. The purge mode must be established in a set order in order to protect the sensors and Calibration modules from damage.

Isolate-Purge Mode Procedure

1. Set the ZOC valve to the Calibrate mode.
2. Set the Calibration module(s) to the Zero Mode. If Scanivalve Corp Calibrator modules are being used in a HyScan system, Steps 1 and 2 can be implemented by setting the Calibrator Module(s) to the Cal Zero Mode.
3. Set the valve(s) to the Purge mode by applying CTLPRG pressure.
4. Apply the Purge pressure.

It is also imperative that a procedure be followed when switching from the Purge mode to one of the other modes.

1. Shut off the Purge pressure.
2. Switch the valve(s) from the Purge mode by removing the CTLPRG pressure.
3. Switch the valve(s) to the desired mode.

MODE	CTL1	CTL2	CTLPRG
Operate			
Calibrate	90 psi	90 psi	
Purge	90 psi	90 psi	90 psi
Isolate	90 psi		

NOTE: Control Pressures may be increased to 120 psi for operation at 750 psi FS

Figure 5 - Control Pressure Truth Table

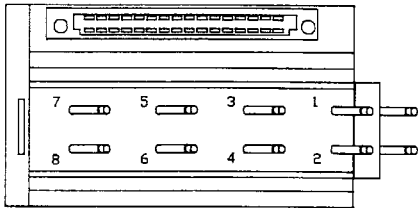

CONTROL PRESSURE TRUTH TABLE

MODE	CTL1	CTL2	CTLPRG
OPERATE*			
CALIBRATE	90 PSI	90 PSI	
PURGE**	90 PSI	90 PSI	90 PSI
ISOLATE	90 PSI		

* NO CONTROL PRESSURE REQUIRED FOR OPERATE MODE.
 ** CALIBRATE MODE WITH BARD ON CAL SUPPLY MUST FIRST BE ESTABLISHED WHEN PURGING.

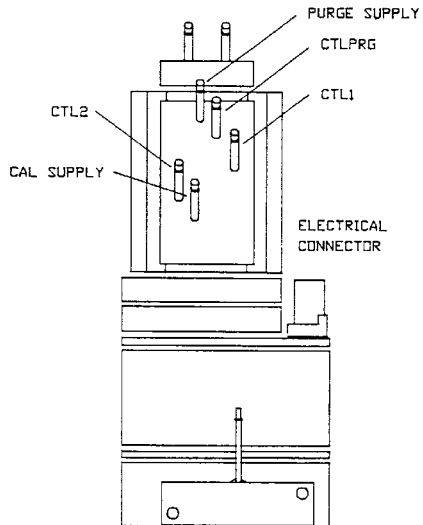
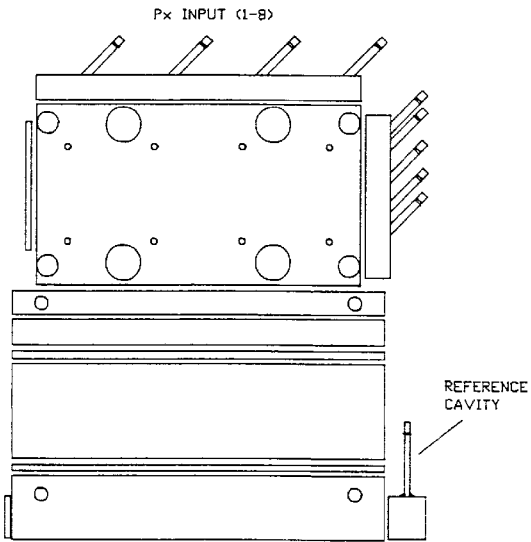

Figure 6 - ZOC17 8 Channel Block

THERMAL CONTROL UNIT

An optional Thermal Control Unit (TCU) is available for applications where temperature swings may be great enough to exceed the compensated range of the sensors and thus induce errors in the pressure measurements. The TCU consists of a housing, insulation and a simple heater which will maintain the temperature of the module at $50 \pm 5 \text{ }^\circ\text{C}$.

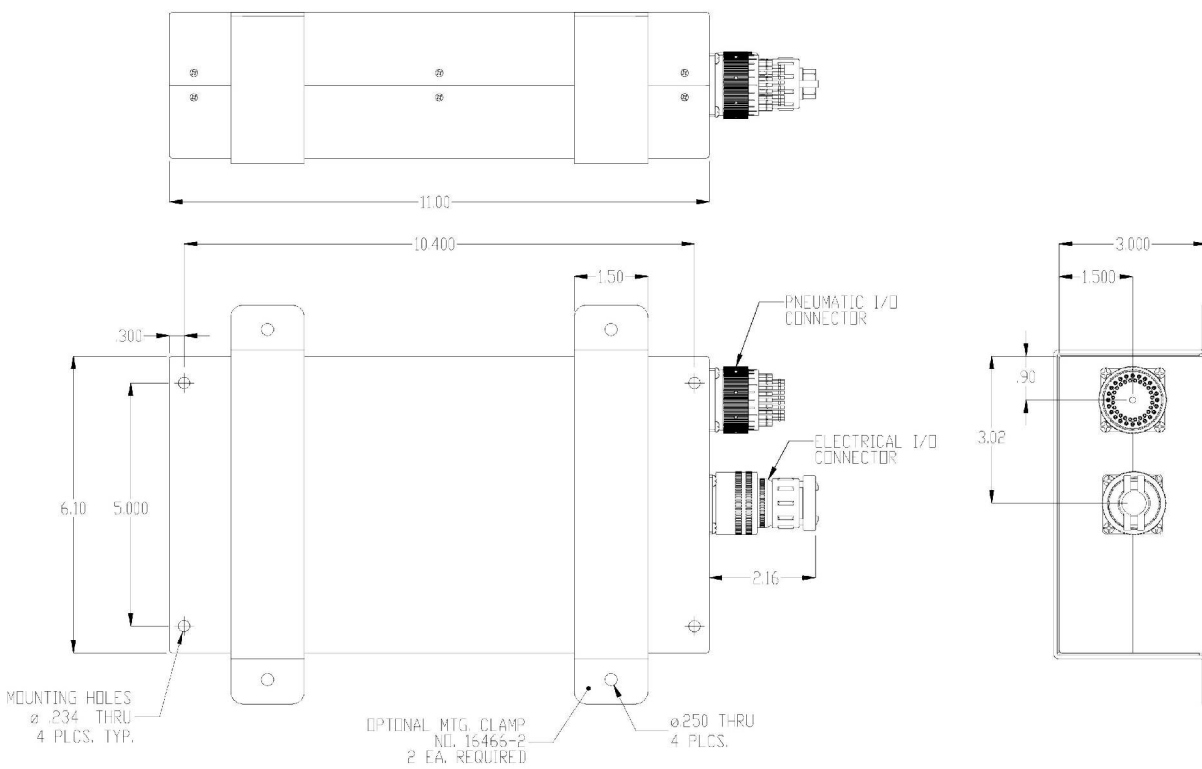

Figure 7 - Typical ZOC17 Thermal Control Unit (TCU)

48ZOCM-1 PORT NO.	ZOC17/16Px	ZOC17/16Px DUAL RANGE	ZOC17/8Px	ZOC17/8DPx	ZOC17/8Px/4DPx
1	1	1 LOW	1	1 POS	8Px-1
2	2	2 LOW	2	2 POS	8Px-2
3	3	3 LOW	3	3 POS	8Px-3
4	4	4 LOW	4	4 POS	8Px-4
5	5	5 LOW	5	1 NEG	8Px-5
6	6	6 LOW	6	2 NEG	8Px-6
7	7	7 LOW	7	3 NEG	8Px-7
8	8	8 LOW	8	4 NEG	8Px-8
9	9	1 HIGH	NC	5 POS	4DPx-1 POS
10	10	2 HIGH	NC	6 POS	4DPx-2 POS
11	11	3 HIGH	NC	7 POS	4DPx-3 POS
12	12	4 HIGH	NC	8 POS	4DPx-4 POS
13	13	5 HIGH	NC	5 NEG	4DPx-1 NEG
14	14	6 HIGH	NC	6 NEG	4DPx-2 NEG
15	15	7 HIGH	NC	7 NEG	4DPx-3 NEG
16	16	8 HIGH	NC	8 NEG	4DPx-4 NEG
17	NC	NC	NC	NC	NC
18	NC	NC	NC	NC	NC
19	NC	NC	NC	NC	NC
20	NC	NC	NC	NC	NC
21	NC	NC	NC	NC	NC
22	NC	NC	NC	NC	NC
23	NC	NC	NC	NC	NC
24	NC	NC	NC	NC	NC
25	NC	NC	NC	NC	NC
26	NC	NC	NC	NC	NC
27	NC	NC	NC	NC	NC
28	NC	NC	NC	NC	NC
29	NC	NC	NC	NC	NC
30	NC	NC	NC	NC	NC
31	NC	NC	NC	NC	NC
32	NC	NC	NC	NC	NC
33	PRG CTL	PRG CTL	PRG CTL	PRG CTL	PRG CTL
34	PRG CH 1-8	PRG LOW	PRG CH 1-8	PRG CH 1-4	PRG 8Px
35	PRG CH 9-16	PRG HIGH	NC	PRG CH 5-8	PRG 4DPx
36	CTL2	CTL2	CTL2	CTL2	CTL2
37	NC	NC	NC	NC	NC
38	NC	NC	NC	NC	NC
39	NC	NC	NC	NC	NC
40	CTL1	CTL1	CTL1	CTL1	CTL1
41	NC	NC	NC	NC	NC
42	NC	NC	NC	NC	NC
43	NC	NC	NC	NC	NC
44	CAL IN	CAL LOW	CAL IN	CAL POS CH 1-4	CAL 8Px
45	NC	CAL HIGH	NC	CAL POS CH 5-8	CAL 4DPx
46	NC	NC	NC	NC	NC
47	NC	REF LOW	NC	CAL NEG CH 1-4	REF 8Px
0	REF	REF HIGH	REF	CAL NEG CH 5-8	REF 4DPx

Figure 8 - ZOC17 TCU Pneumatic Connections

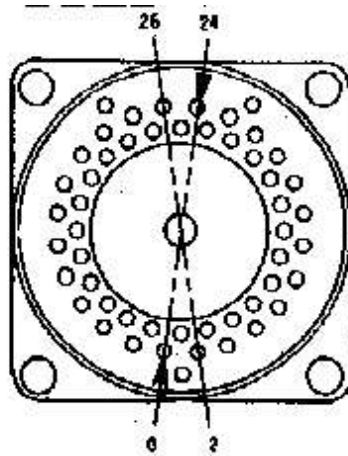

Figure 9 - ZOC TCU Pneumatic Connector

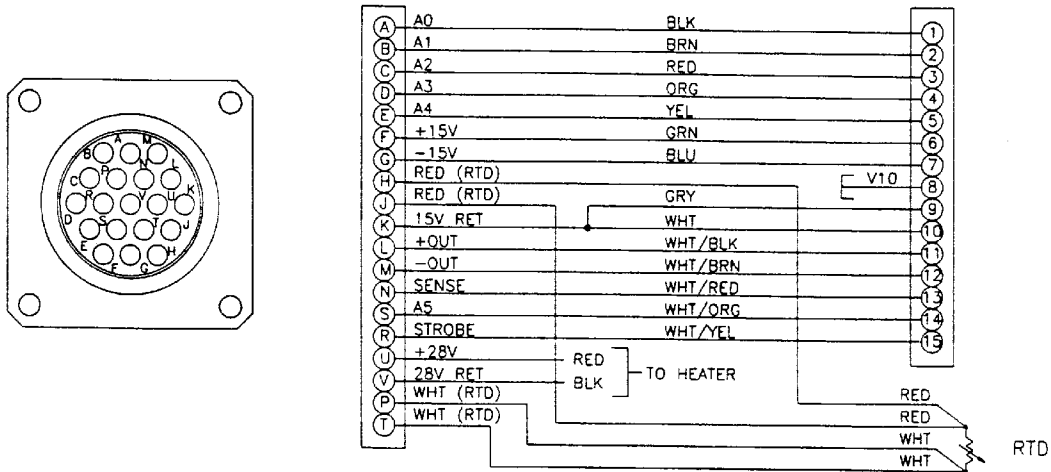

Figure 10 - ZOC TCU Electrical Connections

OPERATION AND INSTALLATION

All ZOC17 modules have been extensively tested prior to shipment. All modules are packed to minimize the chances of shipping damage. However, damage can still occur. The customer must inspect modules and shipping materials for obvious signs of damage. If it is suspected that damage may have occurred, the customer should contact Scanivalve Corp. Technical Services Department immediately.

ZOC17 modules are designed to function best when used with one of the Scanivalve Corp. HyScan Data Acquisition Systems. They can also be used as a stand alone module, with a customer's data system, or with other High Speed Data Acquisition Systems.

Excitation Board

Each block of eight(8) sensors has its own excitation board. The excitation board consists of a precision voltage regulator, eight sockets, eight voltage to current converters and an interface connector. The excitation board is installed above the top jacket.

The excitation board is powered by $\pm 15\text{Vdc}$. This voltage must be regulated, but does not need to be "instrumentation quality". The precision voltage regulator is an LT1019A which converts the $\pm 15\text{Vdc}$ to a precision 10.00Vdc which is used as a reference for the E/I converters. The LT1019A has a very tight output voltage tolerance and a very low temperature coefficient. The E/I converters output a constant 1.5mA to the sensors. Each sensor has its own E/I converter.

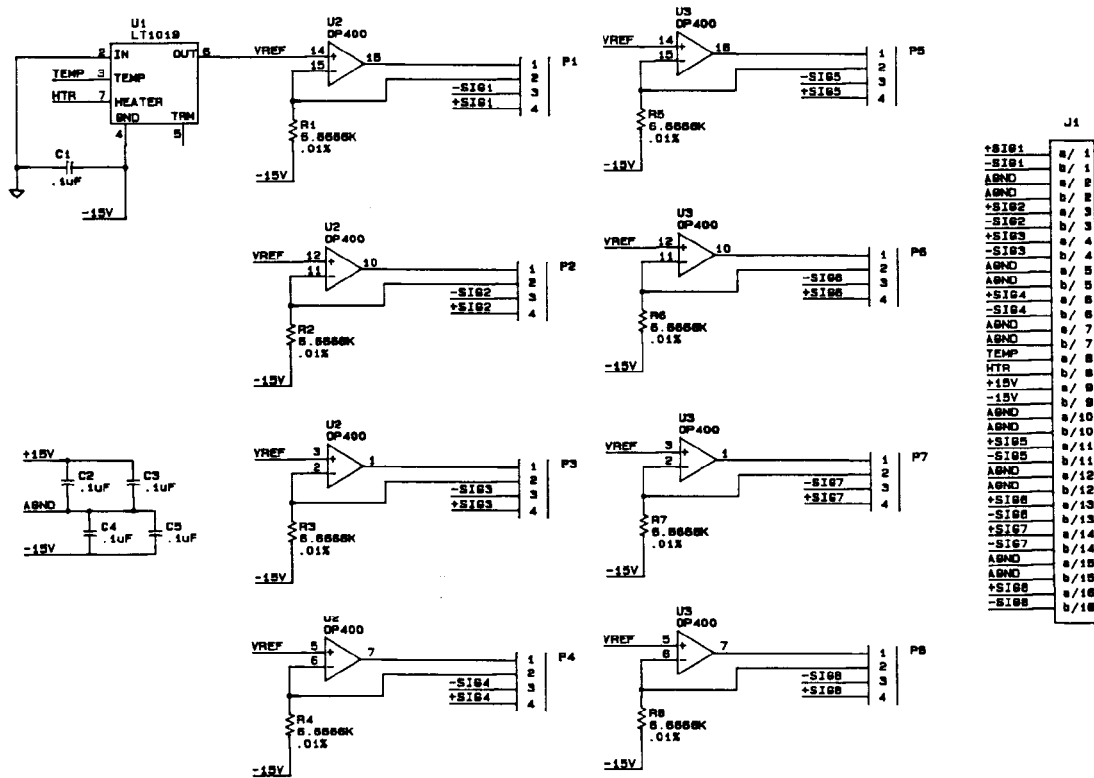

Figure11 - Excitation Board Schematic

Transition Board

The Transition Board is used only in the ZOC17/8Px - Muxless Module. It plugs into the interface connector on the excitation board and adapts the output of the sensors to a 21 pin connector. This connector is compatible with all other ZOC Muxless Module connectors.

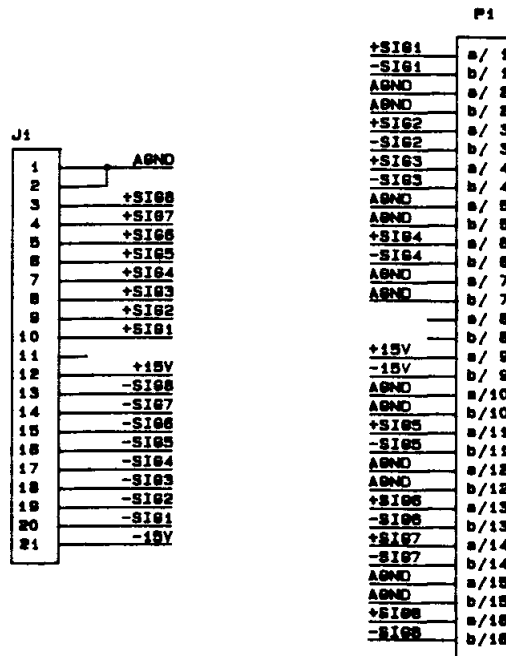

Figure 12 - ZOC17/8Px Transition Board

Amplifier per Channel Board

The Amplifier per channel board (APC) is a special purpose board which is used with a ZOC17/8Px - Muxless module to provide a buffered and amplified output for each individual channel. Each sensor output is amplified to a nominal $\pm 2.5\text{Vdc}$. The actual outputs will fall in a range of $\pm 15\%$ of the nominal output.

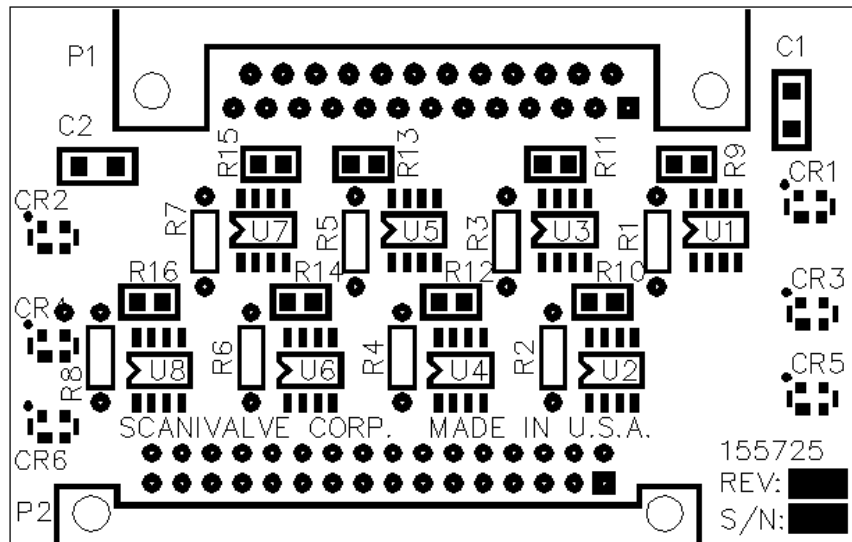

Figure 13 - Amplifier per Channel Board Layout

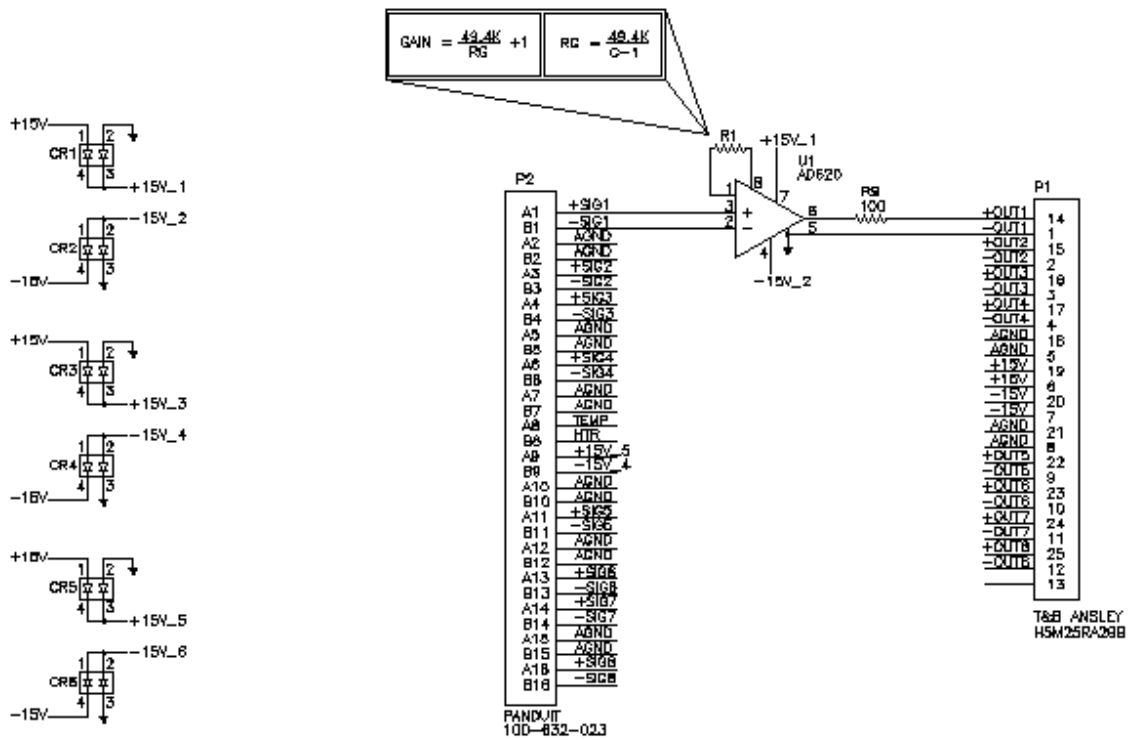

Figure 14 - APC Board Electrical Schematic, Part 1

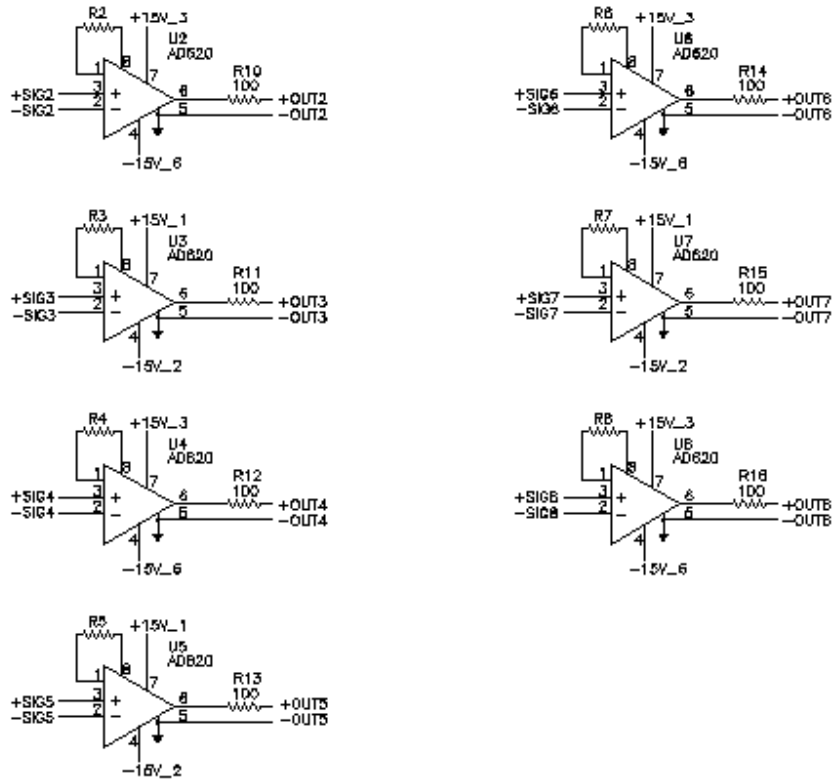

Figure15 - APC Board Electrical Schematic, Part 2

Multiplexer/Amplifier Board

The Multiplexer/Amplifier Board is used only in the ZOC17 Multiplexed Module. The Multiplexer/Amplifier board consists of an input/output connector, two multiplexers, an amplifier, and two interface connectors. The board is powered by $\pm 15\text{Vdc}$. The address lines select a multiplexer and one of eight sensor inputs for input to the Instrumentation Amplifier. The Instrumentation Amplifier amplifies the low level sensor outputs to $\pm 2.5\text{Vdc}$ which is output through the I/O connector. The Amplifier output may be set to $\pm 5\text{Vdc}$ or $\pm 10\text{Vdc}$ as an option.

Figures 16, 17, and 18 show the layout and schematic of the ZOC17 Mux-Amp Board. It is not recommended that the customer attempt to make repairs to the board. The board is a multi-layered board utilizing surface mount technology. Specialized processes are required in order to insure that the board is not damaged during repair. For more information, contract the Scanivalve Corporation Customer Service Department.

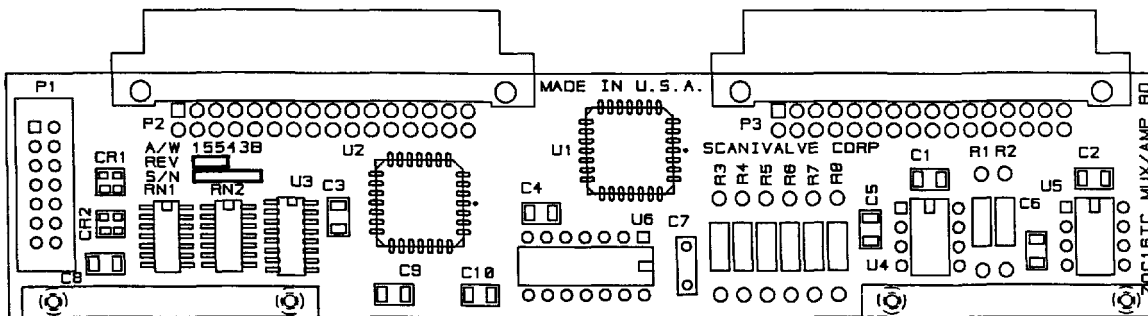

Figure 16 - ZOC17 Mux-Amp Board

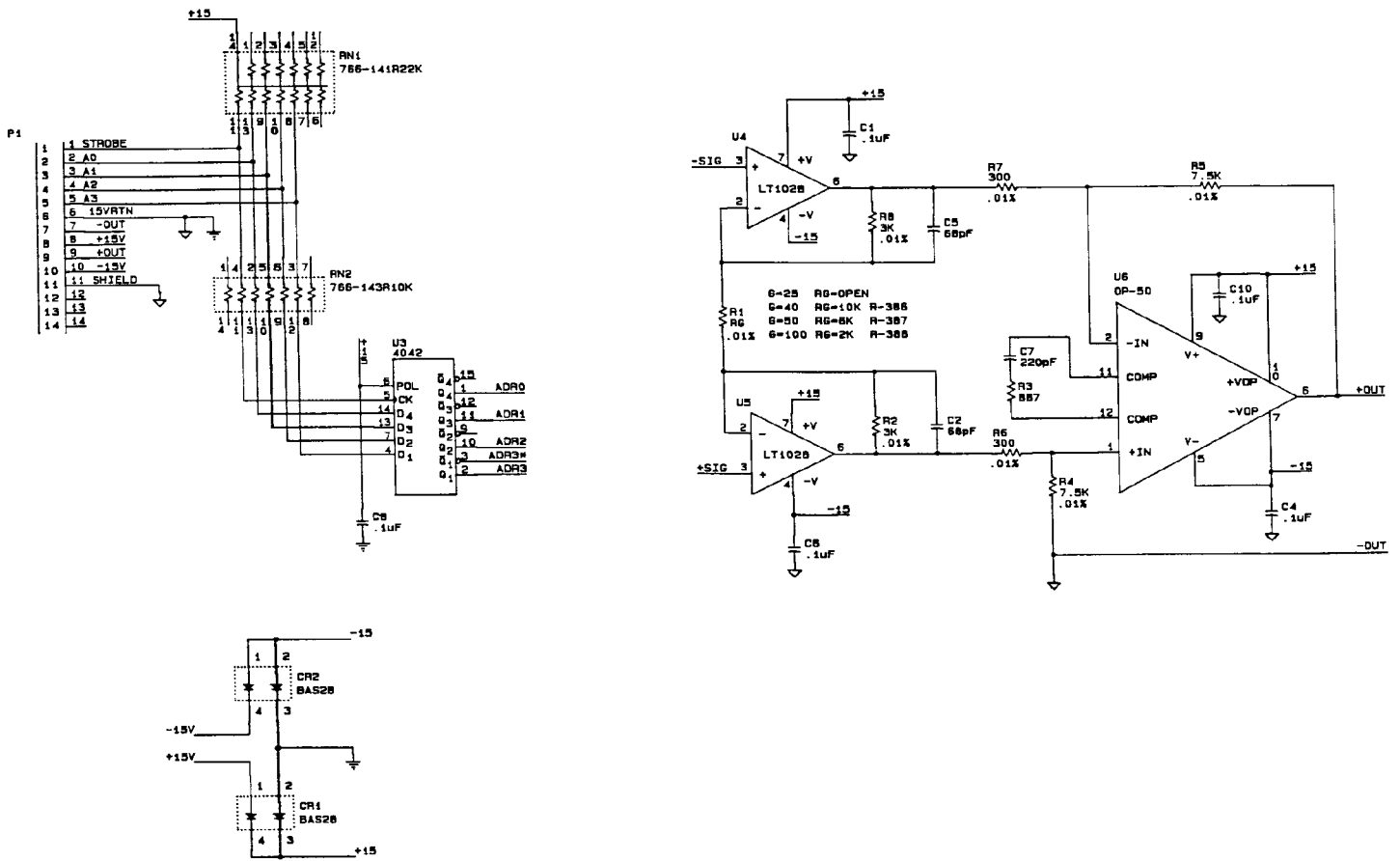

Figure 17 - Mux/Amp Board Schematic

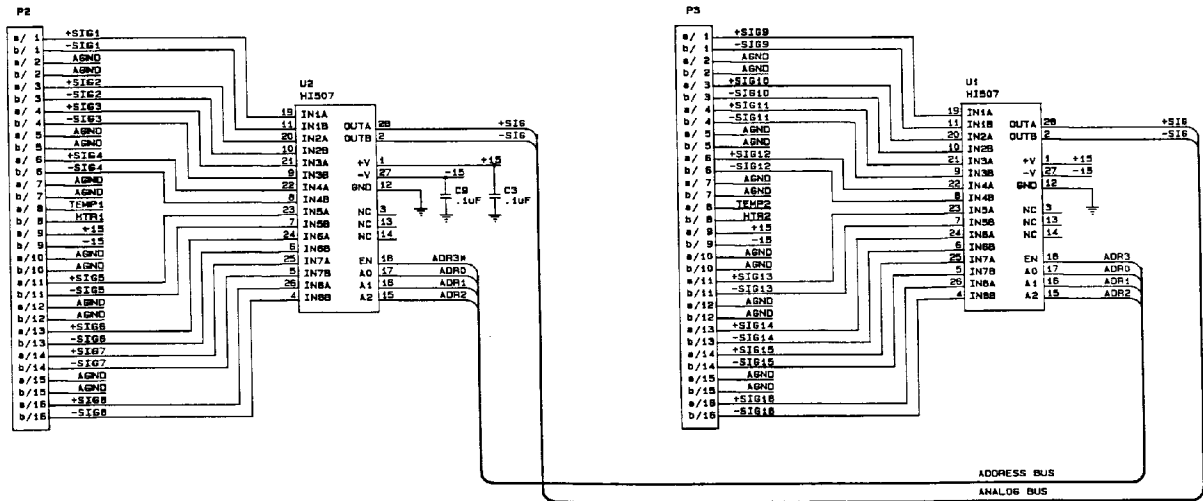

Figure 18 - Analog/Address Bus Schematic

Electrical Inputs and Outputs

The Electrical Input and Output wiring is compatible with all other ZOC modules. The ZOC17 may be installed into existing HyScan Systems without changing configurations.

Figure 19 shows the output connector pin assignments of the ZOC17/8Px Muxless Module.

Figure 20 shows the output connector pin assignments of the ZOC17/8PxAPC Muxless Module.

Figure 21 shows the output connector pin assignments of the ZOC17/16Px Multiplexed Module.

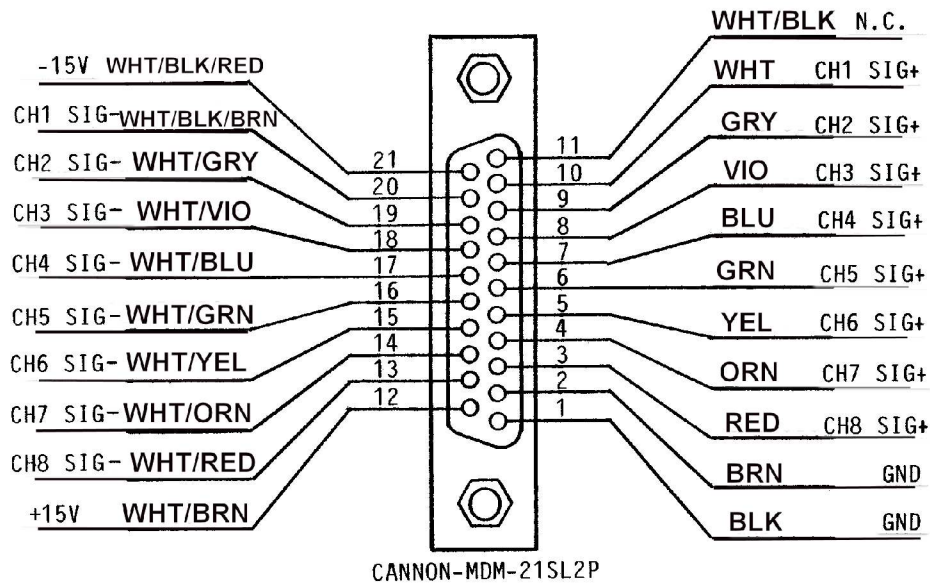
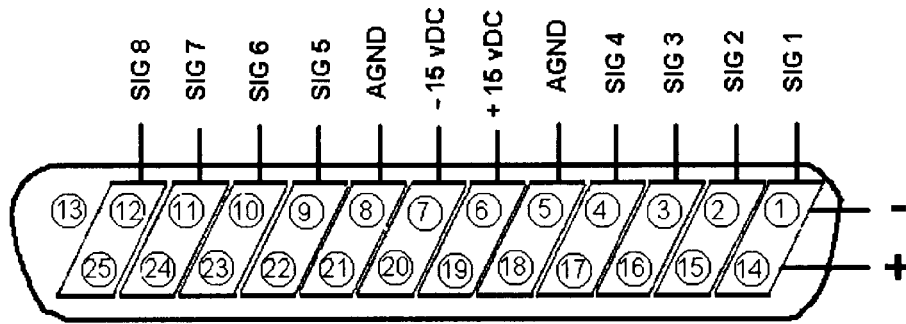

Figure 19 - ZOC17/8Px Output Connector



DB - 25S PINOUT

Figure 20 - ZOC17/APC Output Connector

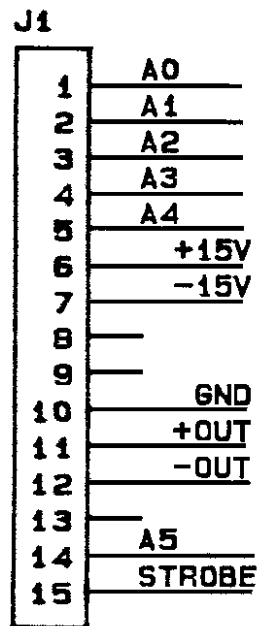

Figure 21 - ZOC17/16Px Output Connector

Pneumatic Inputs

Pneumatic inputs consist of: Px Inputs, Control Pressure Inputs(CTL1 & CTL2), and Calibration/Reference Inputs. Each valve block has its own set of pneumatic inputs.

All Px inputs are .063 inch bulged tubulations. These tubulations are designed to accept any .063 inch tubing manufactured by Scanivalve Corp. Each valve block contains eight(8) Px inputs. ZOC17 modules are capable of measuring pressures up to 500psid.

Control inputs consist of: CTL1 and CTL2. These inputs are used to switch the valve logic to each of the four(4) states: Operate, Calibrate, Purge, and Isolate. The pressure required to switch the valve logic is dependent upon the input pressure. The ZOC17 module family is only available in the ISO-Purge Valve configuration. Figure 21 shows the Iso-Purge Valve Logic.

Calibration/Reference Inputs consist of a Calibration input and a Reference input. The Calibration input is an .063 inch O.D. tubulation. It is normally connected to a source of calibration pressures. Internally, this input is manifolded to all of the sensors through the calibration valving. The Reference input is a .125 inch O.D. tubulation. It provides a point of reference for the transducers. All of the sensors in each block of eight share a single reference.

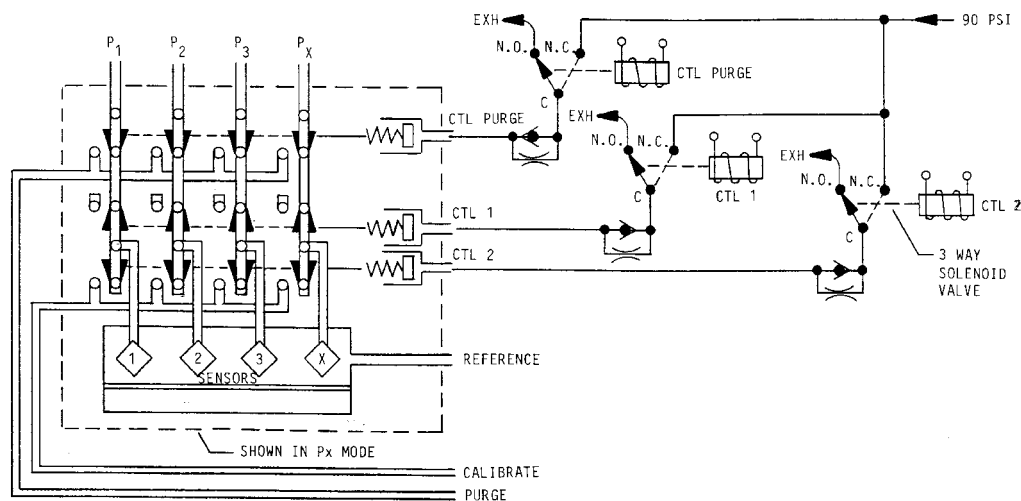

Figure 22 - ISO-Purge Valve Logic

SENSOR INSTALLATION

The sensors used in a ZOC17 module are laser trimmed, temperature compensated sensors. All offsets and spans fall within known limits. This means that a ZOC17 module can be set up to support any full scale pressure range manufactured by Scanivalve Corp. The sensors are field replaceable by a technician with minimum tools. All sensors are labeled and serialized with a color coded label. The sensors plug into sockets on the excitation board from the bottom of the module. A guide pin is located on the sensor which must be lined up with a socket on the excitation board. Detailed instructions for sensor replacement may be found below and are shown in Figure 23. Figure 24 is a cut-away drawing of a typical sensor. Figure 25 shows the labels for each standard pressure range.

1. Position the module on its side with the Reference tube to the top.
2. Position the valve assembly so the tubing is away. Remove the circuit board cover and the circuit board (Transition Board, APC Board, or Mux/Amp Board). Be very careful to avoid Electrostatic problems.
3. With the valve assembly positioned as shown in figure 22, Remove the two bottom screws and the reference manifold.
4. Remove the sensor jacket assembly from the valve body.
5. Remove the sensors to be replaced.
6. Install the new sensors by aligning the guide pin with the mating hole on the excitation board. The guide pin sockets are set toward surface A. Insert the sensor fully so the shoulder of the case is against the shoulder in the sensor jacket.
7. Reinstall the sensor jacket, reference manifold, and bottom screws. Do not overtorque the bottom screws.
8. Replace the circuit board assembly and cover.
9. Perform all applicable operational and leak tests. Refer to the HyScan 1000 or HyScan 2000 Manual for more information.

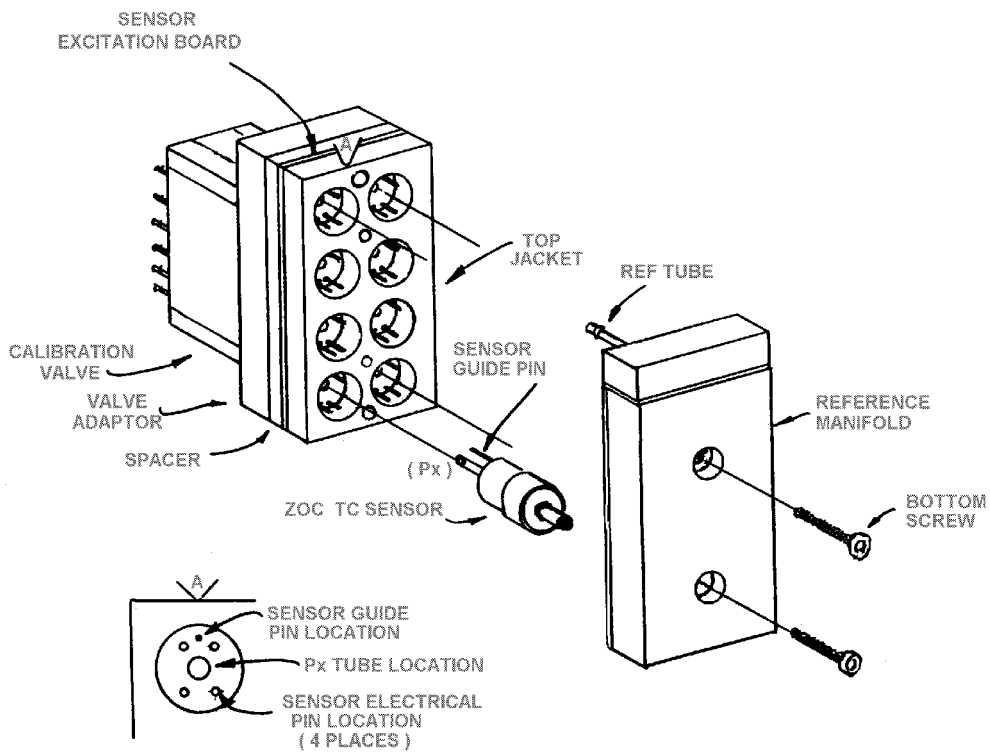

Figure 23 - ZOC17 Sensor Replacement

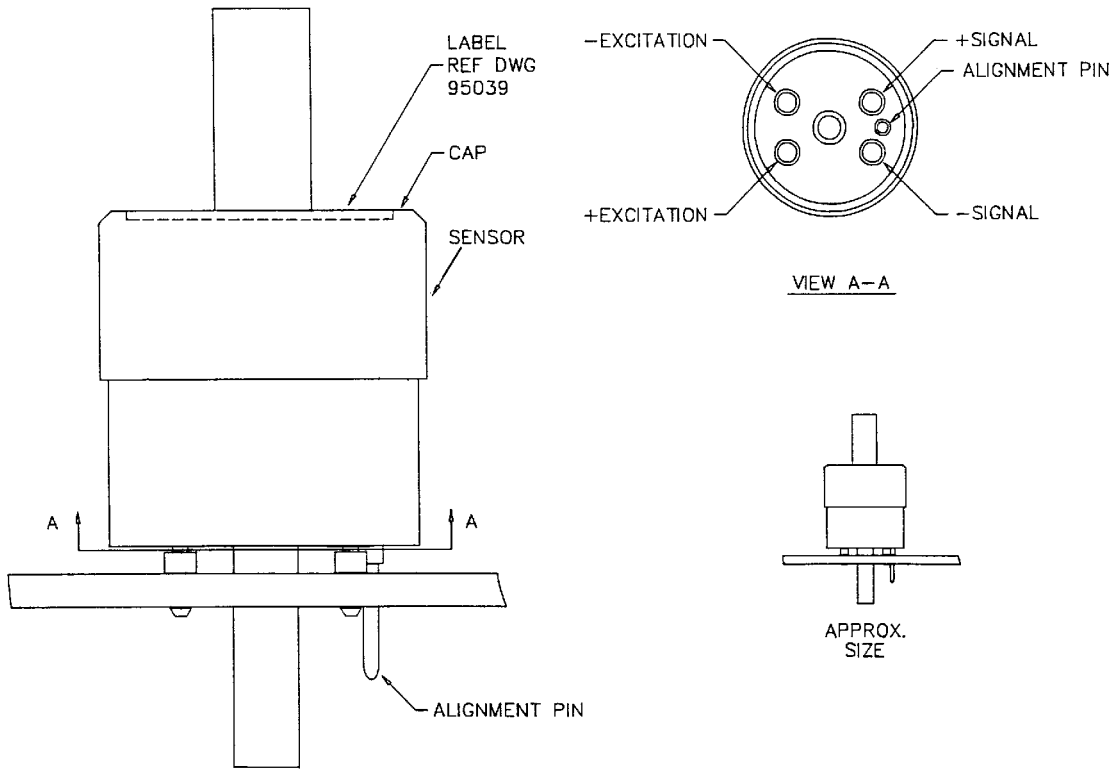

Figure 24 - ZOC Temperature Compensated Sensor

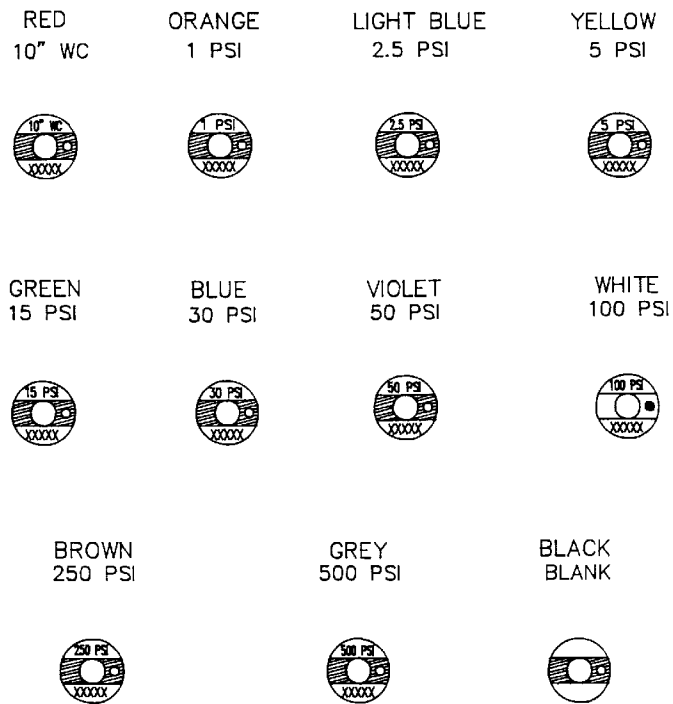

Figure 25 - Identification Labels - ZOC Temperature Compensated Sensors