

## DSA FEATURES

- 0 - 750 psid pressure ranges
- Standard, Dual Range, and True Differential modules available
- $\pm 0.05\%$  full scale accuracy (*most ranges*)
- Temperature compensated pressure sensors
- Isolate / Calibrate / Purge valve

## ENCL FEATURES

- DSP Technology
- Scan rates up to 625Hz (*samples/channel/second*)
- IEEE1588-2008v2 "Precision Time Protocol" compatible
- 3 Integrated solenoids for control pressure
- Data transfers TCP, UDP or FTP
- Up to 128 channels (*8x DSA3016 modules*)

## GENERAL DESCRIPTION

Model DSA3016, Digital Sensor Array, is a rack mounted, analog DSA module designed for multiple pressure measurement applications. Each DSA3016 module incorporates 16 temperature compensated, piezoresistive pressure sensors, along with internal calibration valves, to provide maximum functionality. The valves allow for several logic states including measurement, isolate, calibrate and purge.

The DSAENCL4000 pressure acquisition system represents the next generation of intelligent electronic pressure scanning.

The state-of-the-art DSP technology is at the heart of our new 19 inch rack mounted DSAENCL4000 enclosure. Located on the backplane of the enclosure, the Digital Signal Processor (DSP) is a programmable device capable of extremely fast math functions that operate on the data stream in real time. All measurements are converted into Engineering Units.

Advantages of DSP technology:

- Boots up quickly
- Real Time Operating System
- Low Data Latency

The DSAENCL4000 uses an on-board flash to store all configuration and module data. The enclosure utilizes a pressure temperature look-up table to compensate the pressure sensors for temperature changes, effectively negating any thermal errors.

The DSP processor also controls the actuation of an



DSA3016/16Px-RA  
Digital Sensor Array

internal calibration valve to perform on-line zero calibrations. Long term system accuracy is achieved for up to 6 months.

All DSA3016 modules manufactured after first quarter 2004 have an ID chip installed. The DSAENCL4000 DSP processor reads the serial number and pressure range of each DSA3016 module, and its location in the enclosure all from the DSA3016 module's ID chip.

## APPLICATIONS

The DSA3016 (Digital Sensor Array) is ideal for measuring pressures on turbomachinery, turbine engines, compressors, and other applications where precision pressure measurements are required. The DSA temperature compensated pressure sensors are over ten times more stable over the entire temperature range than typical piezoresistive pressure sensors. Up to 8x DSA3016 pressure modules are supported by a DSAENCL4000 enclosure, totaling 128 pressure inputs per enclosure.

DSA3016 modules have a front panel power cutoff switch that allows them to be "Hot Swappable" without having to power down the ENCL system. They also have an illuminated power switch that blinks when scanning. The DSAENCL4000 enclosure has an Ethernet link and activity LED on the front.

DSA3016 pressure modules can work with all DSAENCL3000, 3200, and 4000 series enclosures.

ISO 9001:2015 CERTIFIED

# DSA3016

## DSA3016 FEATURES AND OPTIONS

### On-line Sensor Compensation and Calibration

The DSA3016 incorporates individual pressure sensors are each uniquely thermally compensated and individually packaged in rugged, field-replaceable housings. Additionally, the transducers are factory calibrated over their full pressure and temperature ranges. The resultant calibration data is stored in a look-up table in FLASH memory.

The design includes integral pneumatic calibration valves, which allows for “quick zero” correction. When actuated, the positive side of the pressure sensors are pneumatically shorted to the reference manifold, creating a zero pressure differential. The sensor offsets are then recorded.

### DSA Valve and Control Pressure

The DSA3016 calibration valves are “Normally Px” where no control pressure, or a loss of control pressure, defaults the DSA calibration valve to the operate (measurement or Px) mode. 90-120psi control pressure is required to switch the DSA calibration valve into purge, calibrate or isolate mode.

A manifold purge feature is incorporated in the DSA calibration valve. This purge method isolates all of the pressure sensors from the purge pressure. It is an ideal method for eliminating condensation, oil, dust or other contaminants in the pressure input tubing. This technique permits the safe use of high purge pressures without damaging the pressure sensors due to overpressure.

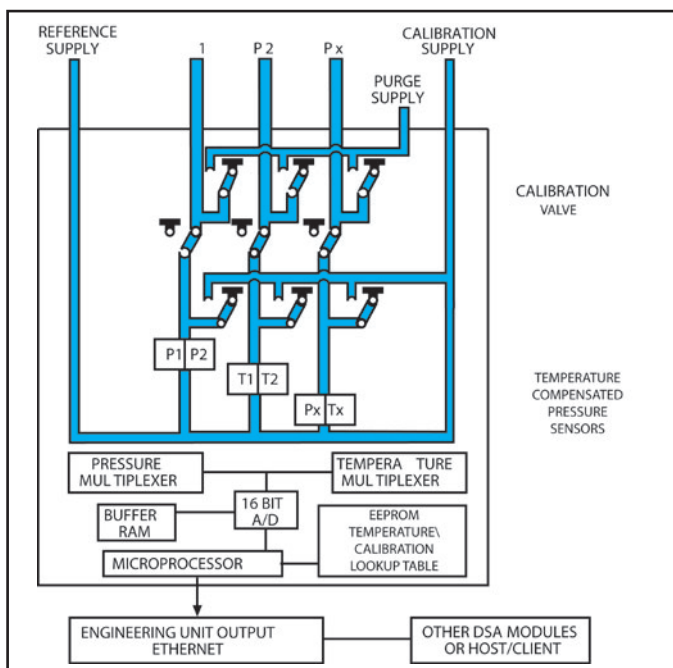

DSA3016  
Front Access

DSA3016  
Rear Access

### Rear vs. Front Access

DSA3016 can be configured with different pneumatic input connections: rear or front access. In rear access modules, or RA, all pneumatic inputs are found on the lower back of the DSA3016, which is then mated to a back block on the ENCL4000. This includes all measurement, control, and calibration inputs. In front access modules, or FA, the measurement inputs 1-16 are supplied on the front face of the DSA3016. All controls, purge, calibration and reference inputs are located at the back of the module. In front access modules, all input are compression fittings (1/8" standard).

### Common vs. Individual Reference

DSA3016 Digital Sensor Arrays are available in two basic model types: common and individual reference. Common reference configurations are standard and allow the user access to each individual sensor's positive side, while the reference (or negative) sides are manifolded in groups of eight. Individual reference versions are available with each sensor having an individual reference input.

### Dual Range

Each group of 8 Px (pressure inputs) contains its own calibration valving and reference connector, thus a single DSA3016 module can incorporate up to two unique pressure ranges for maximum flexibility.

### High-Line Low Delta P Measurements

An optional rack mounted pressure module is available that incorporates a special pneumatic design, which allows for a higher accuracy reading of a low differential pressure measurement under high-line (reference) conditions. Safe zero calibrations can be performed under high-line pressures.

## DSAENCL4000 RACK MOUNT ENCLOSURE

Up to 8 DSA3016 Digital Sensor Array modules are designed to fit in Scanivalve's 19 inch rack mounted enclosures. Each enclosure incorporates a power supply, DSP processor, and multiple 16 bit A/D's to convert all analog pressures to Engineering Units. Communication interface is Ethernet TCP/IP or RS-232. Only 1 IP address is required for each rack mount enclosure (up to 128 pressures).

PMENCL3000 Pneumatic Harnesses can be purchased at time of order. Scanivalve will plumb all control pressures, CAL and REF lines to all DSA3016 modules installed in DSAENCL for system simplicity.

## DSAENCL4000 COMMUNICATIONS

The DSAENCL4000 enclosure interfaces directly to a host computer or Ethernet network via TCP/IP or



DSAENCL4000

RS-232. Primary communications are performed via TCP/IP Telnet and data can be streamed TCP, UDP or FTP. A LabVIEW® Development Kit can be downloaded for users who want to write their own detailed data acquisition program. This Development Kit includes the Configuration Utility software and examples to assist a user in the setup of the system.

## DSA3016 SPECIFICATIONS

### Inputs (Px):

Rear Access:	1/16" bulged tubulations (typical) 1/16" compression fittings (optional)
Front Access:	1/8" compression fittings (std) 1/4" compression fittings (optional)

<b>Full Scale Ranges:</b>	±5 inch H <sub>2</sub> O, ±10 inch H <sub>2</sub> O, 1, 2.5, 5, 15, 30, 50, 100, 250, 500, 600, 750 psid (±1.25, ±2.5, 7, 17, 35, 100, 205, 345, 690, 1725, 3450, 4125, 5175 kPa)
---------------------------	---

### Accuracy\*:

Pressure Range	Static Accuracy (%F.S.)
±5 inch H <sub>2</sub> O	±0.4%
±10 inch H <sub>2</sub> O	±0.2%
±1 to ±2.5psid	±0.12%
±5 to 500psid	±0.05%
501 to 750psid	±0.08%

(Including linearity, hysteresis, and repeatability)

### Overpressure Capacity:

Pressure Range	Overpressure (no damage)
±5 to 10 inch H <sub>2</sub> O	2 psi (13.79kPa)
1 psid	5 psi (35kPa)
2.5 to 499 psid	2x
500 psid	1.5x
750 psid	850 psi (5860 kPa)

**Operating Temperature:** 0°C to 55°C standard

\*Some combinations of pressure ranges in dual-range modules may dictate a reduction in accuracy

### Maximum

**Reference Pressure:** 250 psig (1725 kPa)

**Media Compatibility:** Gases compatible with silicon, silicone, aluminum and BUNA-N

**Weight (typical):** Rear Access: 4.75lbs (2.16kg)  
Front Access: 5.5lbs (2.5kg)

## DSAENCL4000 ENCLOSURE SPECIFICATIONS

### Communication

**Protocol:** TCP/IP, UDP, FTP, IEEE1588v2

### Connector Type:

Comms: RJ-45  
Digital In: Bendix PT06A-12-10S  
Digital Out: Bendix PT06A-12-10P

### Interface:

Ethernet 10/100 Base-T (auto crossover feature)  
RS-232 (9600 Baud)

### Power

**Requirements:** 115Vac @ .87 Amp (100 VA)  
230Vac @ .44 Amp (100 VA)

### Weight:

DSAENCL4000: 19.5 lbs (8.85kg)  
w/ 8 DSA3016-RA: 51.5 lbs (23.4kg)  
w/ 8 DSA3016-FA: 73 lbs (33.1kg)

### Resolution:

16 bit A/D

### Max Scan Rate:

625 samples/channel/second

### Rack Size:

5U, 15" depth

### Pneumatic

### Connections:

1/4" compression for control source  
3/16" push-style for control outputs

# DSA3016 & ENCL4000

## ORDERING INFORMATION

**DSA3016 / 16 Px - 500psid/xxpsid - RA**

### Family & Series

DSA3016  
DSAENCL4000

### Pressure Range\*

(Dual Range example shown)

### Px Inputs\*

RA - Rear Access  
FA - Front Access (1/8" compression standard, 1/4" optional)

### Config\*

16 - 16 channels, standard or dual range (common ref)  
8D - 8 channels, True Differential  
16D - 16 channels, True Differential (FA-Front Access 1/16" fittings only)

\* Not required for DSAENCL4000 part number

## SUPPLIED ACCESSORIES

Each DSA3016 is shipped standard with the appropriate mating back block (for pneumatic inputs) and calibration coefficients.

Each DSAENCL4000 is shipped with a standard 115VAC, 6ft power cable, mating connector for RS232 (DB9) serial, and the mating connectors for digital inputs and outputs.

## Dimensions - Inches [cm]

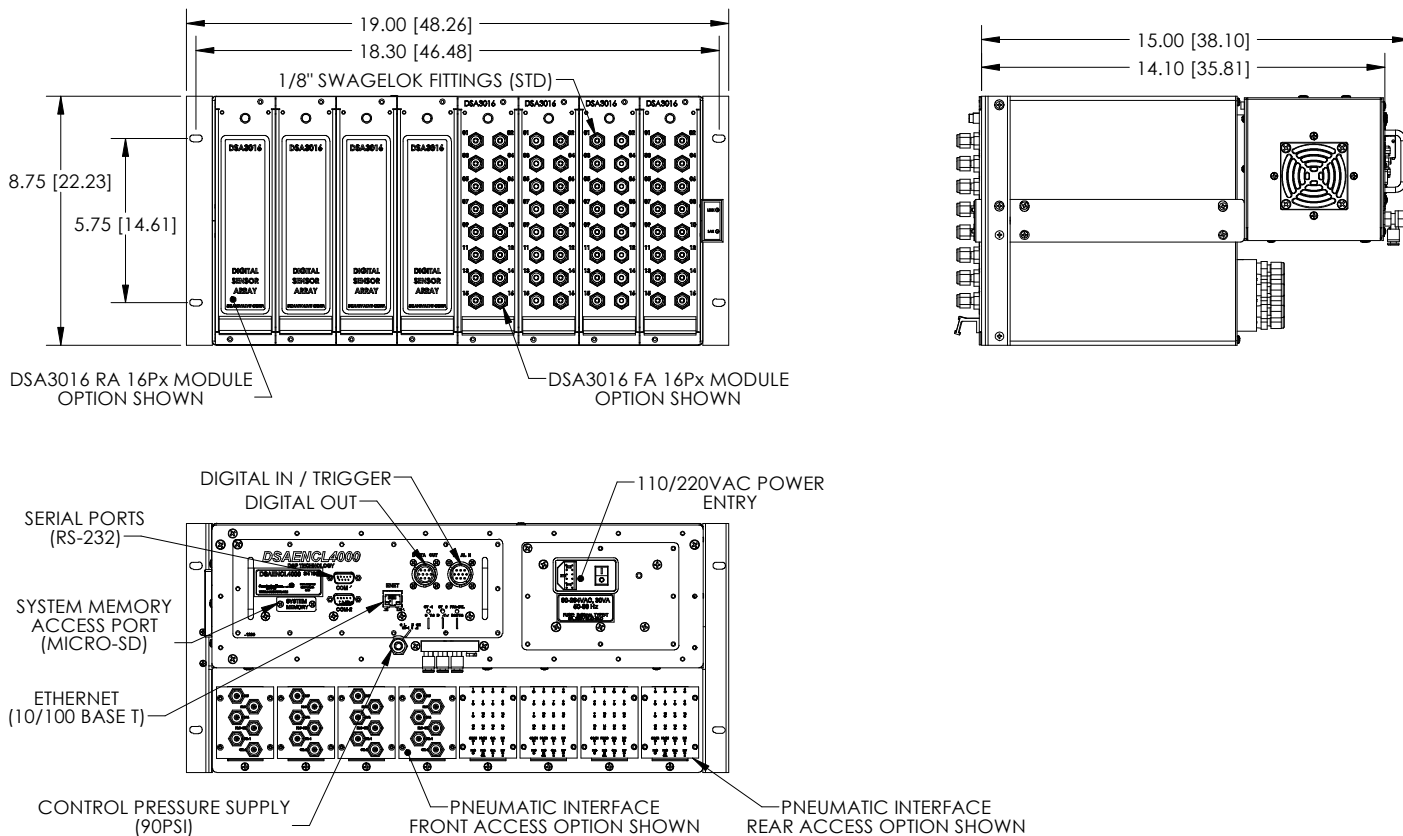

### Scanivalve Headquarters

1722 N. Madson Street  
Liberty Lake, WA 99019  
Tel: 509-891-9970  
800-935-5151  
Fax: 509-891-9481  
e-mail: scanco@scanivalve.com

Printed in USA  
©2021, Scanivalve Corp.

2109

# Scanivalve

[www.scanivalve.com](http://www.scanivalve.com)



Instrumentation Devices Srl

Via Acquanera 29 - 22100 COMO (Italy)

ph +39 031 525 391- fax +39 031 507 984

info@instrumentation.it - www.instrumentation.it