

1000 Nm
1 Channel

FLFM2 Torquemeter

Description

The bearingless system consists of an one-piece measuring body manufactured from a very low hysteresis steel material. The torsion of the measuring segment is registered by means of strain gages, converted into electrical voltage signals, and then transmitted contactlessly via modulated infrared light to the stator. The master frequency is 60 kHz and the span is ± 20 kHz for \pm rated torque.

Temperature related offset shifts are minimized by an active temperature compensation. An optical sensor provides two 90 degree phase shifted speed signals with nominal 600ppr. Maximum frequency is 100 kHz.

An optionally available second transmission track provides an additional second torque measuring range or a multi-channel temperature transmission.



Significant technical data

- Bearingless torque flange with IR-signal transmission
- High overload capability
- Active temperature compensation to reduce temperature effect on zero balance
- Accuracy 0.1 (Option 0.05)
- Optical speed encoder (600 ppr or other)
- Option: 2 torque ranges (span up to 1:10)
- Compact design

Rated torque T_r	Nm	≤ 1000
Overload capability torsional shaft	Nm	$5T_r$
Accuracy including hysteresis and nonlinearity	% FS.	$< \pm 0,1$
Temperature effect on zero	% FS./10K	$< \pm 0,1$
Operating temperature range	$^{\circ}\text{C}$	0...+70
Rated speed	rpm	10,000



**GESELLSCHAFT FÜR
INDUSTRIEFORSCHUNG MBH**
Konrad-Zuse-Str. 3
D - 52477 Alsdorf / Germany
Tel.: +49 - (0)2404-9870-570
Fax: +49 - (0)2404-9870-59
www.gif-ac.com
info.de@gif-ac.com

Technical Data Torquemeter Type FLFM2

TORQUEMETER

Rated torque nominal T_r	Nm	≤ 1000
Torque limit of torque shaft related to T_r	Nm	$> 5T_r$
Rated speed n_r	rpm	10,000
Accuracy	-	0.1
Nonlinearity and hysteresis related to T_r	%	$< \pm 0.1$
Temperature effect on zero per 10K related to T_r	%	< 0.1
Nominal temperature range	$^{\circ}\text{C}$	0...+70
Operating temperature range	$^{\circ}\text{C}$	-10...+80

OUTPUT SPECIFICATION TORQUE

Frequency output	kHz	60 ± 20
Dynamic response up to	kHz	> 1.5
Shunt calibration	-	approx. x % of T_r

OUTPUT SPECIFICATION SPEED

Pulses per rev (optical encoder)	-	300/600
Output signal (RS422)	-	2 tracks 90° $\pm 20^{\circ}$ shifted
Required speed	rpm	> 0

MECHANICAL DATA

Weight (rotor)	kg	2.3
Inertia (rotor)	gm^2	4
Twist angle under rated torque	grad	0.055
Torsional stiffness	kNm/rad	603
Coupling mass (typ.)	kg	7

Order Number

FLFM2-1000-600-KLN

Type _____

Rated torque _____

300/600 Pulses per rev _____

K-Nominal temperature range 0...+70 $^{\circ}\text{C}$
 S-Nominal temperature range -25...+125 $^{\circ}\text{C}$

L-Speed limit up to 0-10,000 rpm
 H-Speed limit up to 0-14,000 rpm (*)

N-Accuracy 0.1
 X-Accuracy 0.05

(*)=without speed detection

Dimensions Torquemeter FLFM2

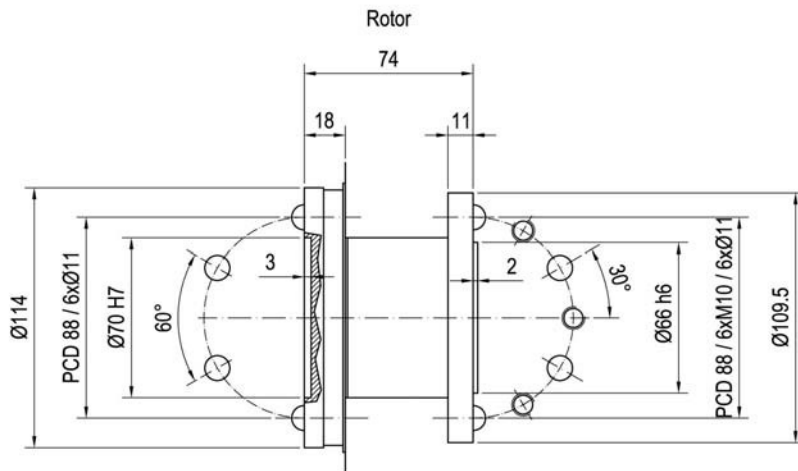
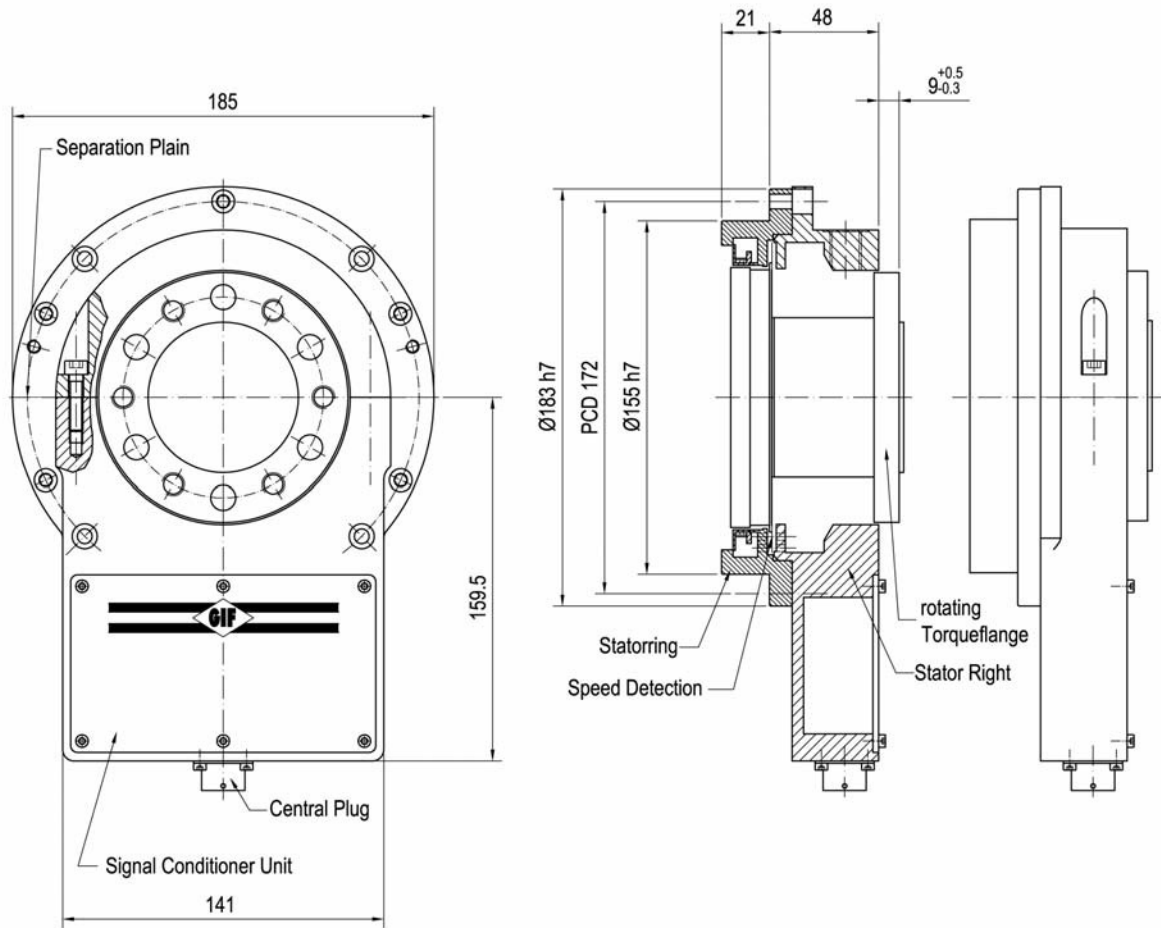

Setup layout and available evaluation units for minimum configuration and operation of torquemeter FLFM2

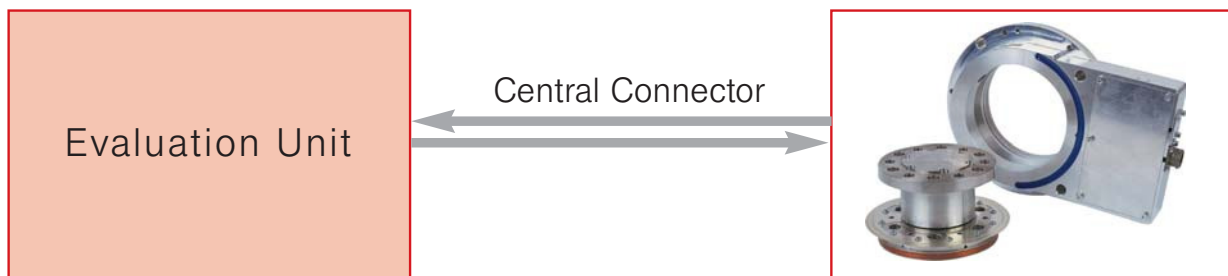

Type: TCU 1



Significant technical data

Power supply 9VDC - 30VDC
 One channel
 Analog output torque sample rate 800 sec⁻¹
 Analog output speed sample rate 800 sec⁻¹
 Serial interface with terminal function
 Interface for external Touch Screen Display
 Diagnostic connector
 Central connector Type ZK 12/12 required

Type: GIF AE...



Significant technical data

Power supply 230VAC, option 115VAC
 One channel
 Frequency output torque and speed
 Analog output torque and speed
 Serial interface with terminal function
 Built-in LC Display (single-line)
 Option: Dynamic plug-in card for torque and speed
 Central connector Typ ZK 12/10 required

Type: TCU 19



Significant technical data

Power supply 115VAC or 230VAC
 One or two channel
 Frequency output torque and speed
 Analog output torque and speed
 Serial interface with terminal function
 Built-in Touch Screen Display
 Free slots for special plug-in cards
 CAN-BUS function
 Central connector Typ ZK 12/12 required

