



4-161

Accelerometers

Velometer, Piezo Velocity Transducer



Applications

- Light Industrial
- Large Fans
- Motors
- Generators
- Pumps

Features

- Two-wire, Current Driven
- Hermetically Sealed
- Velocity Output
- Internally Shielded
- Stainless Steel Body

Description

The 4-161 series velometer is intended to satisfy the general specification requirements for a low cost vibration transducer. Designed for use in multi-point experimental or light industrial vibration monitoring applications, where velocity measurements are required.

The two-wire current loop operating principle permits very long interconnecting cables to be used where necessary and at minimum expense since standard screened pair (or multi-pair) cables may be used.

The piezoelectric sensor and amplifier are contained within an inner metal enclosure which is electrically and thermally insulated from the outer stainless steel body.

This arrangement prevents ground loops and minimizes the effects of thermal shocks and base strain. The inner enclosure is connected to the 0V of the two-wire system and is therefore an effective electrical screen. External connections are made via a top exit integral cable or electrical connector.

The transducer is mounted by means of a single threaded hole in the base of the cylindrical body, this being intended to accept a mounting stud of the standard (non-isolating) type.



4-161 Velometer, Piezo Velocity Transducer

Performance Specifications

Output:	100 mV/inches per second (ips) $\pm 5\%$
Linearity:	Less than 5% at 10 Hz - 1000 Hz (ISO2372 recommended frequencies)
Supply Voltage:	18-30 Volts DC
Cross Axis Sensitivity:	Less than 5%
Frequency Response:	2 Hz to 12 kHz ± 3 dB
Temperature Range	
Operational:	-40°F to +185°F (-40°C to +85°C)
Storage:	-67°F to +250°F (-55°C to +124°C)
Environmental Sealing:	IP67
Temperature Sensitivity:	0.05% per °C
Range:	± 50 ips peak
Mounting Torque:	2 to 5 ft. lbs.
Mounting:	1/4 - 28 Stud (included)
Construction:	Stainless steel case, electrically isolated from internal connections, up to 500 VAC
Weight w/out Cable:	3.0 oz. (90 grams)

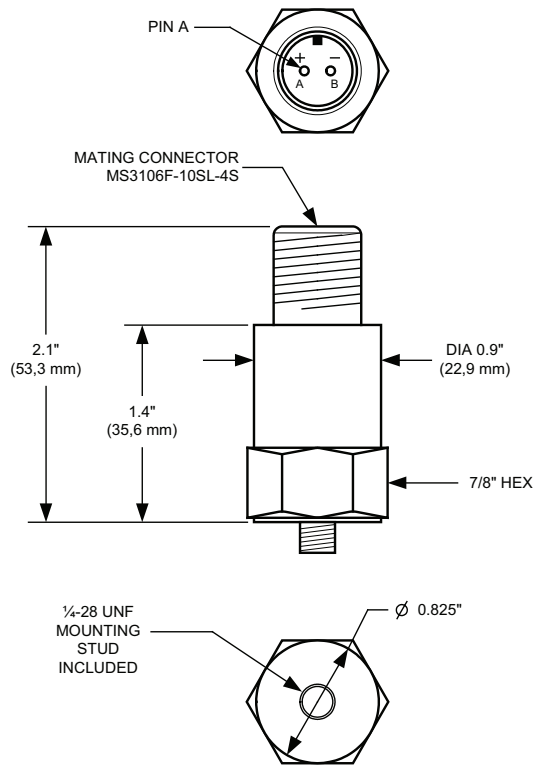

Optional Accessories

1. Mating Connector P/N 619571-1004
2. Cable assembly P/N 780400-91-XXXX (XXXX indicates length in inches e.g.: 10 ft cable = 120 inches is P/N 780400-91-0120).
Assembly includes mating connector to prepared wire.

Ordering Information

Mating connectors and cable assemblies are not furnished and must be ordered separately. In keeping with CEC's policy of continuing product improvement, specifications may be changed without notice. See table below for type numbers and available configurations.

Type	Connection
4-161-1001	Top Connector
4-161-2001-01	Integral 10 ft. cable
4-161-2001-02	Integral 30 ft. cable
4-161-2001-03	Integral 50 ft. cable
4-161-2001-04	Integral 100 ft. cable

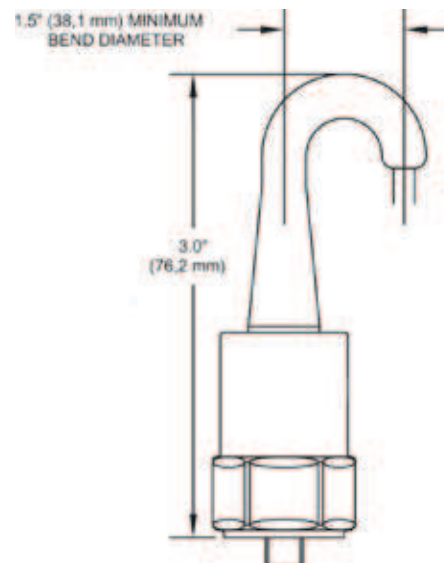

CEC Vibration Products • 746 Arrow Grand Circle • Covina, California 91722 • USA
(626) 938-0200 • (800) 468-1345 • Fax: (626) 938-0202 www.cecvp.com



www.instrumentation.it

Via Acquanera 29, 22100 COMO (Italy) tel. +39.031.525391 - fax +39.031.507984 - info@instrumentation.it

INSTRUMENTATION DEVICES SRL